

OMD™

User's Manual

Heath Consultants Incorporated
Houston, TX
713/844-1300
Fax: 713/844-1309

1-800-HEATH-US
www.heathus.com



*Heath....Leadership, Innovation, Performance
Then, Now and Tomorrow*

Rev E

TABLE OF CONTENTS

SPECIFICATIONS	5
CHAPTER I	
OVERVIEW	7
CHAPTER II	
INSTALLATION PROCEDURE	10
Crossbar Installation	10
Additional Notes On Crossbar Installation	11
Power Box Installation	12
Cable Assemblies Installation	13
Display Installation	14
Display Connectors	15
Vehicle Grounding Strap	15
Protective Cage	16
CHAPTER III	
OPERATING PROCEDURE	18
Start Up	18
Display Function	20
HOLD	20
LIGHT	21
SAMPLE	22
PPM Range	23
Alarm Set Point	25
Error Messages	26
Shut Down	27
CHAPTER IV	
ALIGNMENT PROCEDURE	28
Lamp Alignment	29
Receiver Alignment	30
CHAPTER V	
CALIBRATION CHECK	31
Verifying Calibration With Internal Cell	31
Verifying Calibration With External Cell	32

CHAPTER VI

MAINTENANCE INFORMATION 34
General 34
Recommended Spare Parts 34
Troubleshooting 34

CHAPTER VII

SERVICE INFORMATION 37
Warranty and Warranty Repairs 37
Customer Assistance and Service Locations 38

Appendix A

SURVEY PROCEDURES - MOBILE OMD™ 40

Appendix B

DRAWINGS 55

USING ADOBE ACROBAT READER..... 60

OMD™ System Specifications

Configuration:	Double - ended
Sensitivity:	1 PPM / meter CH4
Measurement Range:	1 to 200 PPM
Accuracy:	± 10% (1 to 100 PPM range) ± 20% (100 to 200 PPM range) Above 200 PPM = Not relatively accurate
Display Ranges:	10, 30 and 90 PPM
Self - test:	During boot – up
Calibration/Test:	Via operator, self - contained
Calibration:	Via RS-232 through software
Base - Line Compensation:	Via RS-232 through software
Display:	Back-lit 2" x 6" graphics LCD, adjustable contrast
Operator Interface:	Sealed membrane switch overlay
Operator Alarms:	
Signal:	High pitch audible with adjustable set point, pitch increases with concentration. Adjustable volume.
Error:	Low pitch audible with adjustable set point
Error alarms provided for:	Warm-up, Low Light, Communication Failure & Battery low
System Power:	72 Watts @ 12 VDC
System Voltage:	12 - 16 VDC

NOTE: To avoid damage to the OMD™ power box, the fuse must be removed prior to charging or jumping the battery in the survey vehicle!

SYSTEM SPECIFICATIONS

System Weight:

External Sub - Systems:	17 pounds
Power Box	6 pounds
Internal Display	3 pounds
Cables	4 pounds
Crossbar Assembly Length:	63.25, 32, 51.25in. \pm 2in.
Mechanical Mounting:	Strut bracket mount
Installation Time:	2 hours, typical
External Housing Rating:	NEMA 3S and IP 54
Display Housing Rating:	Spill proof
External Sub -	
System Materials:	Aluminum and plastic
Environmental PCB Control:	Conformal PCB coating
Operating Temperature	
Range:	- 22°F to 122°F
Operating Humidity Range:	5 to 100 % RH, non-condensing

Chapter I

OVERVIEW

The Optical Methane Detector (OMD™), is the first of the “next generation” leak detection systems which address the high cost presently associated with leak surveying. This new technology combines sensitivity, selectivity and speed through the combined use of optics and electronics. The OMD is mounted on the front of a survey vehicle and detects the presence of methane in air. It provides for the detection of gas leaks down to 1 part per million (PPM). It has no moving parts that will prevent the instrument from operating. It requires no support gases and is virtually maintenance free.

Based on the absorption of infrared (IR) radiation by methane, the OMD consists of an IR light source directed at an IR optical detector. These two are spaced approx. four feet apart across the width of the vehicle. An optical filter in front of the detector transmits primarily methane specific IR wavelengths from the light source. In the absence of methane, these wavelengths are unaffected and produce a steady output signal from the detector. When the vehicle passes through a plume of natural gas, methane in the plume will absorb some of the IR light reaching the detector. As a result there is a sudden decrease in IR light at the detector causing a decrease in detector output. This change in detector output is transmitted to the display panel located next to the vehicle’s driver and becomes a signal, both audio and visual. Gas concentration is calculated in the OMD by converting the methane to light ratio to PPM. The data is displayed in both analog and digital form. The analog display appears as a peak scrolling across the display screen. The OMD will also detect other hydrocarbons such as ethane and propane but with less than half the sensitivity.

OVERVIEW

The OMD operates reliably under a variety of environmental conditions including dry weather, snow, ice and temperatures from -22° F to +122° F. Its sensitivity, calibration or response is not affected by small fluctuations in the light beam or by reasonable amounts of dust, or snow on the optics. An internal calibration test cell is included so the operator can verify proper operation from the vehicle cab at any time before, during or after a leak survey. An Installation Mounting Kit is available for mounting the OMD to the front of a vehicle. All interconnecting cabling is provided with the OMD including the cable to obtain power to operate the instrument from the survey vehicle 12 volt battery. An RS232 port is included whereby a personal computer may be connected to acquire and save the survey data with the appropriate software.

Depending on local meteorological conditions, a given amount of gas escaping from the ground will produce a plume that varies in size and uniformity of concentration levels. The plume, of its very nature, defies quantification by fixed or moving detectors. Regardless of these uncertainties, it is of paramount importance to be able to detect gas when gas is present. Concentration levels of the measured gas are of interest, but are of secondary importance. Consequently, the ability of a detector to detect the plume with accuracy and precision is not as important as its ability to do so with good sensitivity (or a low detection limit) and with a minimum of false alarms.

There are two kinds of false alarms: false negatives and false positives. False negatives occur when a leak is missed. The detector is saying there is no gas present when, in fact, a leak was present but undetected. False positives occur when the detector says that a gas leak is present when it really is not. Examples of false positives experienced include the detection of

auto exhaust and swamp or sewer gas. Due to the selectivity of the OMD, false positives caused by auto exhaust are greatly minimized.

NEW

Experienced operators should use their discretion. Operators should take into account that the wind must be favorable, towards the path of the OMD light bar, to obtain the optimum results. Increased speed from FID survey comes from the instantaneous response of the OMD; however, there are a variety of factors to consider such as, legal limits, terrain and inclement weather for the OMD operation. Please refer to the GPTC Guide for Transmission and Distribution Piping Systems: 1998-2000 Guide Material Appendix G-192-11 Section 4 Leak Detection, 4.4 Leakage surveys and test methods (a) Surface Gas Detection Survey. Part (3) Utilization. The use of this survey method may be limited by adverse conditions (such as excessive wind, excessive soil moisture or frost or surface sealing by ice water). The survey should be conducted at speeds slow enough to allow an adequate sample to be continuously obtained by placement of equipment intakes over the most logical venting locations, giving consideration to the location of the facilities and any adverse conditions which might exist.

Chapter II

INSTALLATION PROCEDURE

It is virtually impossible to predict the exact installation procedure for every different type of vehicle on the market. There are some details that will have to be worked out on the spot with your particular vehicle and here are a few ideas to consider.

There are five parts to consider when installing the OMD: 1) The crossbar assembly, 2) The power box, 3) The cable assemblies, 4) The display unit, and 5) Vehicle Grounding Strap.

Crossbar installation:

The OMD components are pre-aligned at the factory and should not require re-alignment when the system is installed on the vehicle. It is, however, important that the u-bolts be attached in such a way that they do not bend the support rod. The u-bolts should be tight enough to hold the OMD crossbar securely in place, but not so tight as to distort the crossbar. If that happens, re-alignment may be required. We recommend using only two insulated u-bolts to mount the OMD crossbar to minimize the possibility of distorting the crossbar. The following procedure will generally work best.

For your convenience, we have put together an OMD mounting kit, which includes strut channels, shelf brackets, u-bolts and mounting hardware (Heath P/N 2510651).

Use two strut channels that are approx. 24" long each (Heath P/N 2510652). These strut channels are mounted vertically to the front bumper of your vehicle, parallel to each other and approx. three feet apart. It is most fortunate if you have a front bumper that is relatively flat vertically, in which case the strut channels can be mounted directly to the bumper. If the bumper

is not flat, some other type of brackets, supports, etc. will need to be used to attach the strut channels to the front of the vehicle. Mount the two strut channels approx. one-foot from the ground to the bottom of each strut channel. A drawing is included in Appendix A.

Once the strut channels are mounted, use standard strut channel shelf brackets (Heath P/N 2510654) to mount to the strut channels with two bolts (Heath P/N 2510655) and channel-nuts (Heath P/N 2510653) each. The OMD crossbar can then be attached to the shelf brackets with the insulated u-bolts provided (Heath P/N 2510657).

Once this installation is complete, the height of the OMD can easily be adjusted by loosening the bolts attaching the shelf brackets to the strut channel and sliding the OMD up or down to the desired position. In addition, the shelf brackets can be mounted facing upward so that the OMD can be extended another 10" up toward the hood. The shelf brackets can also be mounted downward so that the OMD can be extended another 10" down toward the ground.

Additional Notes On Crossbar Installation:

One of the most important points to consider when installing the crossbar assembly is air-flow. Unlike the flame ionization technology, which has a vacuum pump to bring the sample to the analyzer, the OMD relies strictly on the flow of gas through the optical path. Therefore, it is of the utmost importance that you install the OMD in such a way as to allow the gas to flow continuously through the optical path. It is important that you don't configure your mounting brackets in a way that creates a dead space thus preventing gas from flowing freely across the optical path. A drawing illustrating this problem is included in

Appendix A at the end of this manual. Many vehicles have vents below the bumper to allow airflow into the engine compartment. This is a good place for the optical path. If you attach the OMD crossbar at bumper height, then hang the optical path slightly below the bumper and gas will flow across the optical path then on into the engine compartment.

The best location for your OMD crossbar assembly will vary from vehicle to vehicle. However, one principle remains the same, install the crossbar in such a way as to allow gas to freely flow across the optical path.

Power box installation:

The original suggestion was if the vehicle had sufficient room, that the Power Box should be mounted under the hood. This reasoning was to eliminate the need for routing multiple cables into the vehicle cab. However, field experience indicates that in some instances, heat from the vehicle engine coupled with high ambient temperatures can result in Power Box failures. The current suggestion is to mount the Power Box inside the cab of the vehicle. The first thing to consider when mounting the power box inside the cab is cable length. The standard cables are at least long enough to mount the power box directly behind the front seat on most vehicles. If you desire to mount it further back, check the length from the desired mounting position to the OMD crossbar assembly mounted in front of the front bumper.

After determining where you want to mount your power box, simply place the box in the desired spot and mark through the mounting holes on the ears of the box with a pencil. Drill starter holes, then attach the box with four # 8 x 1/2" sheet metal screws.



Cable assemblies installation:

Each cable assembly for the OMD is uniquely constructed so that it cannot be connected to the wrong mating connector. First, you will need to determine which cable goes where. If you mounted the power box under the hood, then you will only need to route the display cable either through the firewall or through the floorboard. If you mounted the power box inside the cab, you will need to route the other three cables into the cab as well.

Unless a hole large enough to route the cabling through already exists, you will need to drill one. A hole approximately 1-1/8 inches in diameter should be sufficient to route one or three cables. A 1-1/8 inch rubber grommet should be used in this hole to protect the cables from damage. A 1-1/8 inch rubber grommet may be purchased from Heath as P/N 2510686.

INSTALLATION

When routing cables from the cab to the front of vehicle, fasten the cables to fixed parts of your vehicle with tie wraps. Tie wraps are available from Heath as P/N 9996350 for 4" (per 1,000) and P/N 0419180 for 8" (each). Be sure to route cables away from exhaust components and shift linkages.

The OMD requires six amperes of continuous current. So connect the system power cable to the vehicle's battery. Do not connect the system power cable to the cigarette lighter or anywhere else that is not rated for at least six amperes. When connecting power, polarity must be observed. If the positive and negative leads are reversed, the fuse will blow immediately. The red wire should be connected to the positive terminal and the black wire connected to the negative terminal of the battery.

Note:

Connect the battery cable up last. Be sure that the receiver cable is connected prior to making the battery connection. Damage to the electronics may occur if not properly connected

Display installation:

The requirements for installing the display include mounting the display at an operator friendly height and position and then plugging in the display cable. A floorboard mounting pedestal or a dash-board console are two possible mounting methods. These types of devices are available from suppliers of cellular phone equipment.

Display Connectors:

There are three connectors on the side of the display box. The first is for the system cable which comes from the power box connector marked “Display.” Next is the RS-232 connector, which is to connect a computer for data logging, etc. Then there is a 1/8” phone jack for connecting an external speaker. When a phone plug is plugged into the speaker jack the internal alarm speaker is disabled.

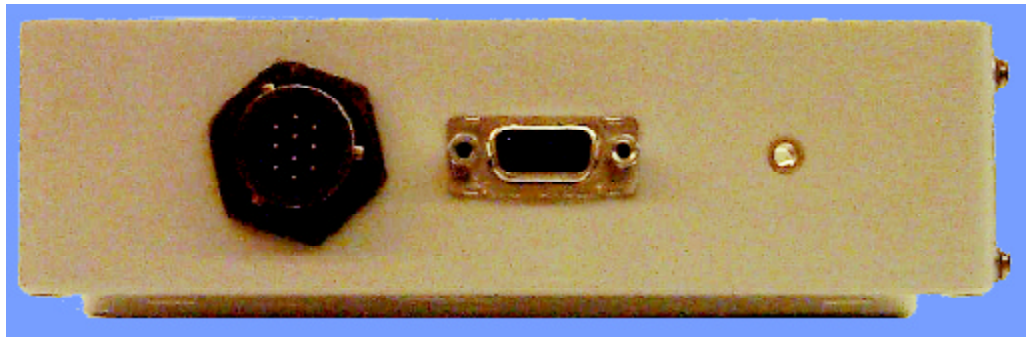

Vehicle Grounding Strap

A vehicle-grounding strap is included in the OMD mounting kit. The purpose of this strap is to prevent the buildup of an Electro-static charge, thereby preventing any condition of Electro-static discharge between the operator and the display unit, which can cause a reset condition of the display unit. The ground strap mounting location on the vehicle is at the discretion of the customer. To ensure proper operation, however, certain conditions need to be observed.

- Ground strap must be mounted to the vehicle chassis. Avoid mounting to any surface that is painted or plated.
- Ground strap should have a minimum of three inches of the strap in contact with the surface being traveled over.

INSTALLATION

·Verify that the mounting location of the strap will not cause it to come in contact with any rotating parts, such as drive wheels or drive shaft.

NOTE: Ground strap mounting hole is .475"ID and strap length is 30".

Protective Cage

Because the main part of the OMD is located on the front bumper of the survey vehicle, it is in danger of being damaged due to the possibility of bumping into something. We recommend that a cage be built around the OMD to protect it.

It would be nearly impossible to build one cage that would fit on every type of vehicle used for mobile surveying. Therefore Heath does not offer one at this time. We recommend that you take your vehicle to a local fabrication shop to custom build one for your vehicle.

Following are a few photos of typical protective cages presently in use.



Photos of Protective Cages

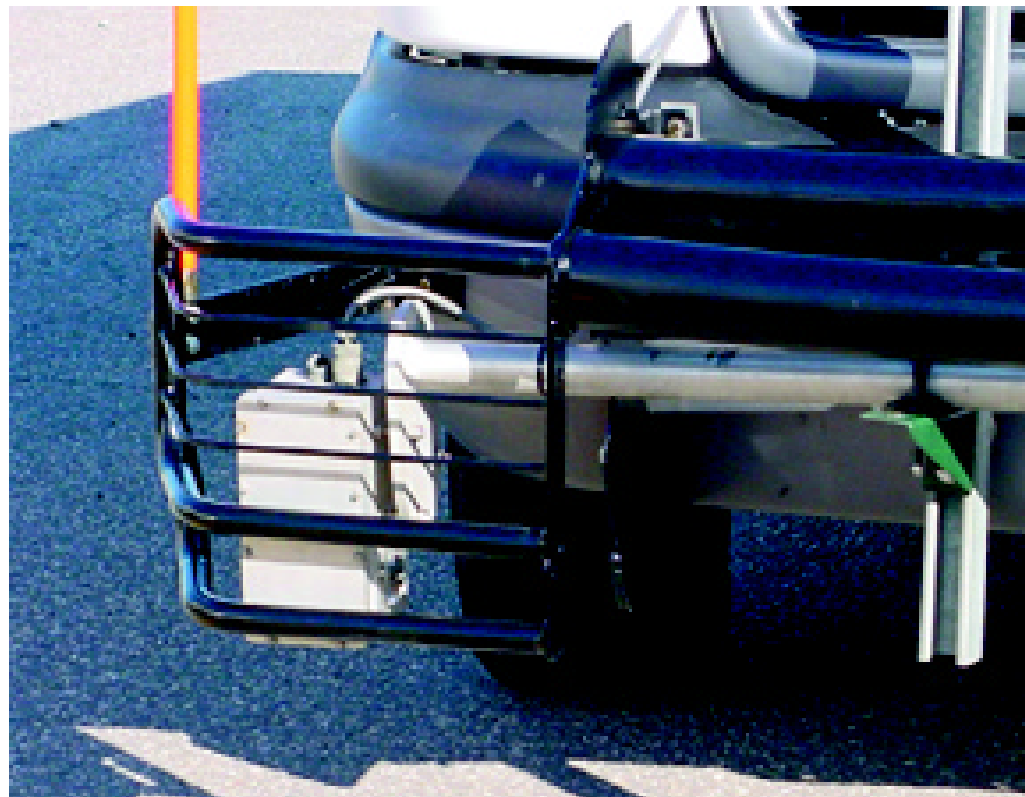

Chapter III

OPERATING PROCEDURES

Start Up:

- 1) Turn on the SYSTEM POWER by pressing the “SYSTEM POWER” button. The red LED above the SYSTEM POWER button will light up and a message will appear on the screen stating, “PUSH DISPLAY FUNCTION TO CONTINUE.” Press the Display Function button twice to enter the normal operating mode.

If the system has been off for more than several seconds, a “SYSTEM WARMING UP,” message will be displayed. The system will require up to approximately 15 minutes before a beep will be heard and a message prompting the operator to, “TURN ON THE LIGHT SOURCE” will be displayed.

- 2) Turn on the LIGHT SOURCE if not done so already by pressing the “LIGHT SOURCE” button. The red LED above the LIGHT SOURCE button will light up and normal operation of the system will begin. If the vehicle will be turned off for a break, turn off the LIGHT SOURCE to save the automobile battery, while keeping the System Power on. A message prompting the operator to turn on the LIGHT SOURCE to resume operation will be displayed. System current consumption with the light is approximately five amperes while system current consumption without the light is less than one and one half amperes, which can be sustained by a good automobile battery, without the use of the engine, for at least 12 hours without causing starting problems. However, extreme cold conditions may require the vehicle to remain running as battery capacity drops significantly with reduced temperature.
- 3) Allow time for the instrument to stabilize. This may take 45 to

60 minutes. The system is stable when the PPM readings become consistent.

- 4) Press the CALIBRATION TEST button. The red LED above the CALIBRATION TEST button will light up and a small internal cell containing methane will be placed in the optical path. This test cell will remain in the light path for approximately five seconds unless the button is held down. After five seconds the cell will return to its normal position and the red LED will turn off. The increase in methane above the background should be shown on the calibration data sheet that was shipped with your instrument. In other words, if the baseline on the display at the time of the calibration is 2 PPM and the calibration data sheet indicates that the calibration cell contains the equivalent of 15 PPM of gas, an increase in signal level from 2 to 17 PPM will be expected when the CALIBRATION TEST button is pressed. Some deviation from this exact number is acceptable as indicated by the range on the data sheet. It is good practice to occasionally press the CALIBRATION TEST button during the daily operation of the system to insure that the system is operating properly.

The concentration of the gas within this test cell is actually much higher than the reading listed on the data sheet. The reading obtained from this test cell is equivalent to the reading of a gas cloud that fills the entire volume within the light path, that is, the volume between the lens on the lamp assembly and the lens on the receiver assembly.

- 5) Set the Audible ALARM SETPOINT by pressing either the ALARM SETPOINT UP or DOWN button. The audible alarm will be sounded if the present methane level is greater than the ALARM SETPOINT level. Holding either the up or down ALARM SETPOINT button will enable the auto scroll

OPERATING PROCEDURES

- 6) Set the SPEAKER VOLUME of the alarm to the desired level by pressing either the SPEAKER VOLUME INCREMENT or DECREMENT button to raise or lower the SPEAKER VOLUME. Holding either the up or down SPEAKER VOLUME button will enable the auto scroll feature. If needed, press the CALIBRATION TEST button to introduce a gas alarm.
- 7) Adjust the CONTRAST to the desired level by pressing either the CONTRAST UP or DOWN button to raise or lower the CONTRAST control to maximize the visibility of the display. Holding either the up or down CONTRAST button will enable the auto scroll feature.

DISPLAY FUNCTION:

The DISPLAY FUNCTION has three modes- HOLD, LIGHT & SAMPLE. These modes are entered by consecutively pressing the DISPLAY FUNCTION button to scroll through each. Beginning with HOLD, as you continue to press the button the mode changes from HOLD to LIGHT to SAMPLE and back to HOLD again, as indicated by the direction of the arrow.

HOLD:

This is the power up default position indicated by the line under the word HOLD. This position will stop the updating of the methane level vs. time. This allows the operator to inspect the display before it scrolls off the screen. This is especially important in one-person survey operations as the driver may hold the display while finding a place to pull off the road. A message prompting the operator to “PUSH DISPLAY FUNCTION TO CONTINUE”, will be displayed. The display will be cleared when the DISPLAY FUNCTION button is pressed again, leaving

the HOLD mode. The following picture shows the OMD in the HOLD mode.

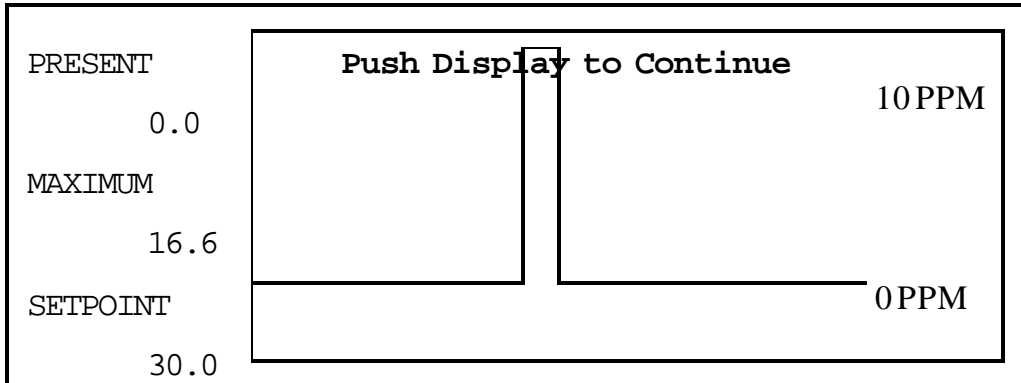

LIGHT:

In this position, numbers in the range from 0 to -1200 are displayed, indicating the amount of light reaching the detector with the lower numbers (more negative) indicating the highest light levels. This is illustrated in the following figure.

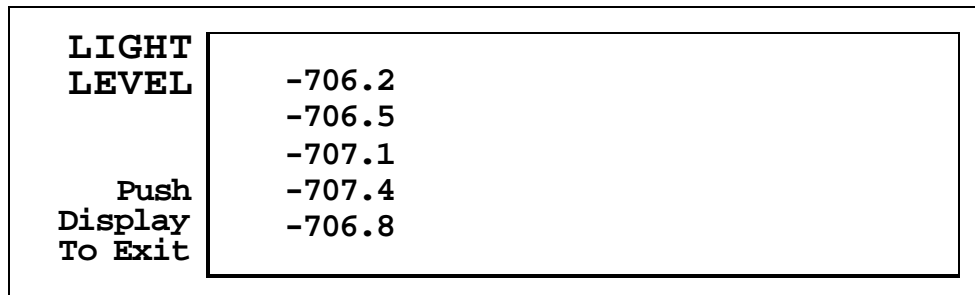

The calibration data sheet shows the number range typical for this system when the lenses are clean. The light level can be decreased by the amount of accumulated water and dirt on the lenses. This is normal and the system will remain in calibration and maintain its sensitivity to methane. If the light level goes below a low limit, the LOW LIGHT alarm will be activated at the level indicated by the data sheet that was shipped with your instrument. At that point it may be necessary to clean the lenses.

OPERATING PROCEDURES

Use a soft, lint free cotton towel to clean the lenses. The light level is also affected by the alignment of the Light Source and the Receiver. The components have been pre-aligned before they are shipped and normally do not require realignment. However, if the mounting brackets used to attach the system to a vehicle distort the cross bar between Light Source and Receiver, realignment may be necessary. The alignment procedure will be discussed later in this manual.

SAMPLE:

This is the normal operating mode. With the DISPLAY FUNCTION in this position, the display will show a one-minute time history of the methane level. The right-most point displayed is the most recent, and the display scrolls to the left. If no errors are present, the left side of the display will show the “PRESENT” methane level at the top left corner of the LCD. This is the peak PPM level sensed in the last 1/2 second. At the left center of the LCD the “MAXIMUM” methane PPM level is shown. This is the maximum peak that has been sensed and is still scrolling across the screen on the display (approximately one-minute). At the bottom left of the LCD the present ALARM SET POINT for the audible alarm is displayed. The following picture shows the OMD™ in SAMPLE mode when it has just begun to sense 9.3 PPM of methane.

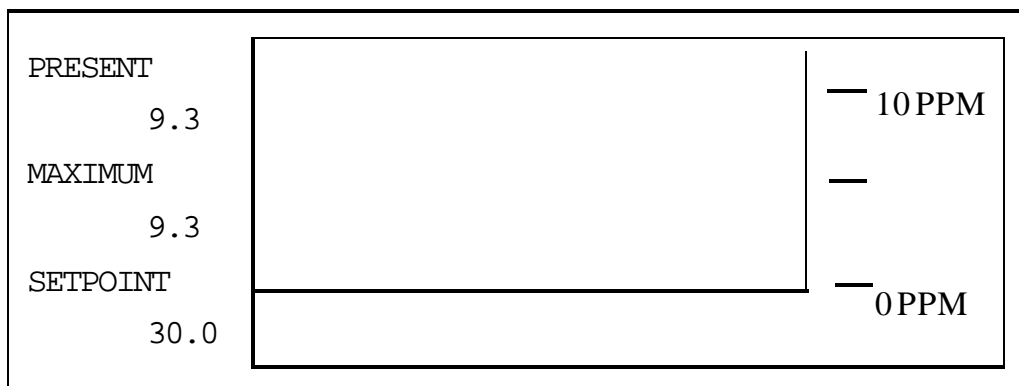

PPM RANGE:

Consecutively pressing the PPM RANGE button allows the formatting of the display with full-scale settings of 10, 30, or 90 PPM. The ranges will actually display to slightly higher values up to 13, 40, and 120 PPM. The PPM RANGE button changes the scale at all times that the time history of the methane level is displayed, including DISPLAY HOLD. The digital readout of gas concentrations on the left side of the display will indicate the gas concentrations over 200 PPM independent of the setting of the PPM RANGE button. The PPM RANGE button only changes the amplification of the one-minute history on the right hand side of the LCD.

The “90” range is the power up default position indicated by the line under the number 90. Press the button to change the range from 90 to 30 to 10 and back to 90 again, as indicated by the direction of the arrow.

Following are some examples of the same size leak being displayed in each of the three ranges.

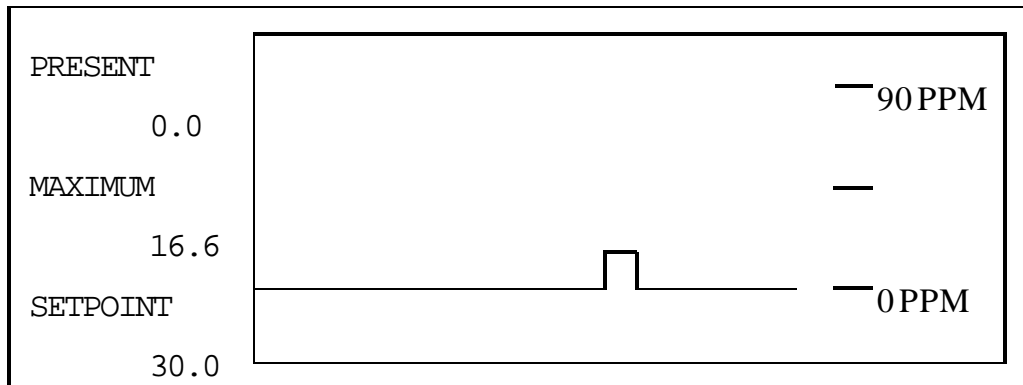

Here is a 16.6-PPM leak displayed in the 90-PPM range.

OPERATING PROCEDURES

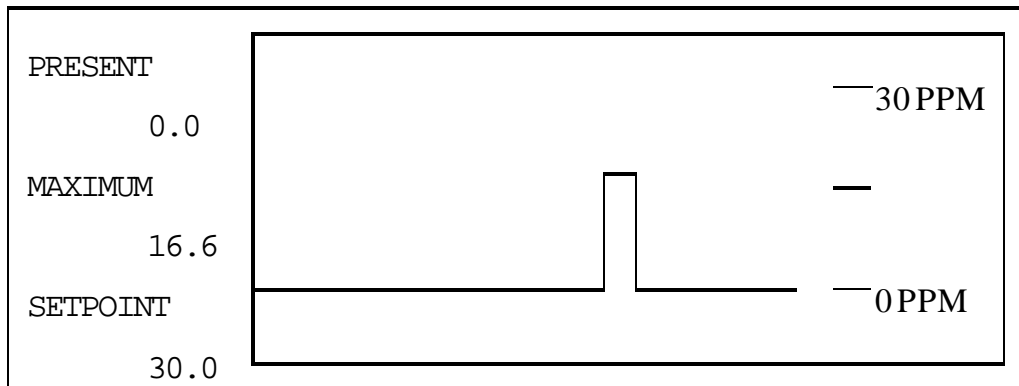

Here is a 16.6-PPM leak displayed in the 30-PPM range.

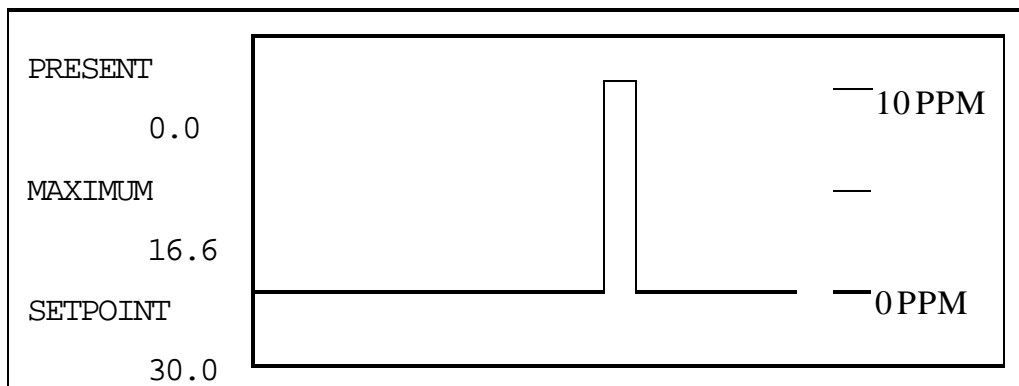

Here is a 16.6-PPM leak displayed in the 10-PPM range.

ALARM SETPOINT:

The audible alarm allows the driver to only respond to significant events, rather than requiring constant observation of the methane level. The ALARM SETPOINT may be adjusted to the required level greater than the normal background level. Changes in the background level may require changes in the ALARM SETPOINT. The background level may be a value more or less than zero. If the background level changes significantly (more than 4 PPM), contact Heath for further instructions. The ALARM SETPOINT is adjustable from -10 to +40 PPM in 2-PPM increments, with the value preset to 30 PPM when the system is first turned on.

CAUTION:

IT IS NOT RECOMMENDED THAT YOU ALLOW THE ALARM TO BEEP CONTINUOUSLY FOR AN EXTENDED PERIOD OF TIME. THIS COULD CAUSE PREMATURE FAILURE OF THE ALARM BUZZER. THIS IS COMMON WHEN YOU GET OUT OF THE VEHICLE TO VERIFY A LEAK. YOUR VEHICLE COULD BE PARKED CLOSE ENOUGH TO THE LEAK THAT THE OMD™ BEGINS TO PICK UP THE LEAK AND START ALARMING WHILE THE OMD IS UN-ATTENDED. WHENEVER YOU LEAVE THE VEHICLE, PRESS THE DISPLAY FUNCTION BUTTON TO REMOVE THE DISPLAY FROM SAMPLE MODE TO PREVENT CONTINUOUS ALARMING.

ERROR MESSAGES:

When a concentration of methane greater than the ALARM SET POINT enters the light path, a *high pitched* alarm is sounded. The higher the concentration of methane, the higher this pitch becomes.

If any errors are present, they will be displayed instead of the levels, and a low pitch alarm sound will be heard. The possible errors are WARM UP, LIGHT, FAILURE and BATT LOW.

The WARMUP error will occur if the LIGHT SOURCE is turned on before the system temperature has stabilized at its set point, or if a malfunction in the system has occurred. If the error remains for more than 15 minutes, turn off the system and contact Heath.

The LIGHT error will occur when the light level is not sufficient due to an obstruction of the light path (i.e. dirt or another obstruction) or when the light bulb fails. If the LIGHT error occurs, press the DISPLAY FUNCTION button to place the instrument in the LIGHT mode and observe the numbers.

When this number drops below the alarm set point (typically -200), the LIGHT alarm will occur. The optics may be cleaned, if necessary, to improve the light intensity. If cleaning the lenses does not correct the problem, a mechanical re-alignment may be necessary.

A FAILURE alarm will occur when the electronics has detected an abnormal condition. This may occur when communicating with a PC through the serial port. If you are not using the serial port and the FAILURE error is displayed, turn off the SYSTEM POWER and contact Heath.

The BATT LOW alarm occurs when the vehicle battery is below approximately 12 volts. Check the battery and the battery terminal condition if this error is displayed.

CAUTION:

BECAUSE OF INHERENT LIMITATIONS, LIQUID CRYSTAL DISPLAYS SHOULD NOT BE SUBJECTED TO EXTREMES OF TEMPERATURE OR HUMIDITY. IF THE INSTRUMENT IS EXPOSED TO A TEMPERATURE BELOW FREEZING OR ABOVE +49°C (120°F) THE LIQUID CRYSTAL DISPLAY MAY TEMPORARILY CEASE TO FUNCTION PROPERLY AND IN SOME CASES PERMANENT DAMAGE MAY RESULT. IT IS RECOMMENDED THAT THE INSTRUMENT NOT BE SUBJECT TO EXTREME CONDITIONS, SUCH AS A CLOSED VEHICLE IN DIRECT SUNLIGHT OR CONTINUOUS SUBFREEZING TEMPERATURES.

SHUT DOWN:

At the end of the workday, press the SYSTEM POWER button to turn off all power. A typical standby current of 50 Miliamps is required when the OMD is “OFF”. This is normal and will not cause any problems.

Chapter IV

ALIGNMENT PROCEDURE

In order for your OMD to function properly, it is crucial that the optical path be aligned properly. The OMD components are pre-aligned at the factory and should not require re-alignment when the system is installed on the vehicle. It is, however, important that the u-bolts be attached and tightened such that they do not bow the support rod. The u-bolts should be tight enough to hold the OMD crossbar securely in place, but not so tight as to distort the crossbar. If that happens, re-alignment may be required. This alignment can be done fairly easy in the field by following this procedure.

There are no adjustments to be made inside the Receiver or the Light Source. The design relies on the mechanical tolerances to place the components in the proper place. Final alignment makes use of the external alignment screws on the Light Source and the Receiver.

To be aligned, first clean the light source and receiver input lenses. Turn on the system power and press “Display Function” on the display until “LIGHT LEVEL” appears. With the light source on and the light path clear of all obstacles, this number should be close to the number that appears on your data sheet (+ or – 20). If this number differs by more than 50 (closer to zero), it is a good indication that your OMD needs to be re-aligned.

Lamp Alignment:

The alignment process starts by using the alignment screws on the Light Source to visually center the light beam on the Receiver lens.

Then, the alignment screws on the Receiver are used to optimize the light level as observed on the Display. This last step directs the optical beam through the optical components of the Receiver to the Detector.



Place a piece of tracing paper in front of the receiver input lens and you will be able to see the rectangular shaped light beam projected onto the lens as well as the outline of the lens itself. If this light beam is not projecting onto the receiver lens at its center, adjust the alignment screws on the back of the light source until it is.

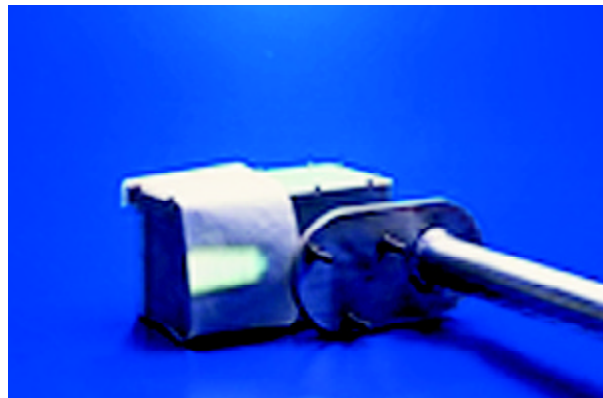

ALIGNMENT

Receiver Alignment:

Next, remove the paper and clear the light path of all obstacles. Observe the “LIGHT LEVEL” on the display. The alignment screws on the Receiver are used to optimize the light level as observed on the Display. Adjust the receiver alignment screws until the light level reaches its most negative number. This last step directs the optical beam through the optical components of the Receiver to the Detector. Be sure to tighten all nuts on lamp and receiver after alignment.



LIGHT LEVEL	-746.2
	-756.5
	-767.1
	-777.4
Push Display To Exit	-786.8

Chapter V

CALIBRATION CHECK

It should be noted that the OMD, like all survey instruments, is not designed for absolutely accurate quantitative analysis. It is designed for leak surveying. Its purpose is to find leaks as small as one (1) PPM. The OMD has an accuracy rating of $\pm 10\%$ within a range of 1 to 100 PPM. The accuracy drops to $\pm 20\%$ within the range of 100 to 200 PPM. Above 200 PPM the OMD is not relatively accurate.

If your OMD varies from calibration by more than $\pm 10\%$ within a range of 1 to 100 PPM there is something wrong with the instrument, and it should be examined by a trained technician. The calibration of the OMD must be verified at the beginning of each workday to insure the instrument is functioning properly.

Verifying Calibration with Internal Check Cell:

Before verifying functionality of your OMD, the optical path should be clean and aligned properly and the system should be thoroughly warmed up (**approx. one hour**). The internal check cell should be used on a daily basis to verify that the functionality is remaining consistent. If the value of the internal check cell should vary significantly (± 5 PPM) from previous readings, your OMD might need to be calibrated. However, the best approach is to use an external calibration cell to verify calibration. This hermetically sealed cell can be purchased as Heath P/N 100138-0. Below is a picture of this cell.

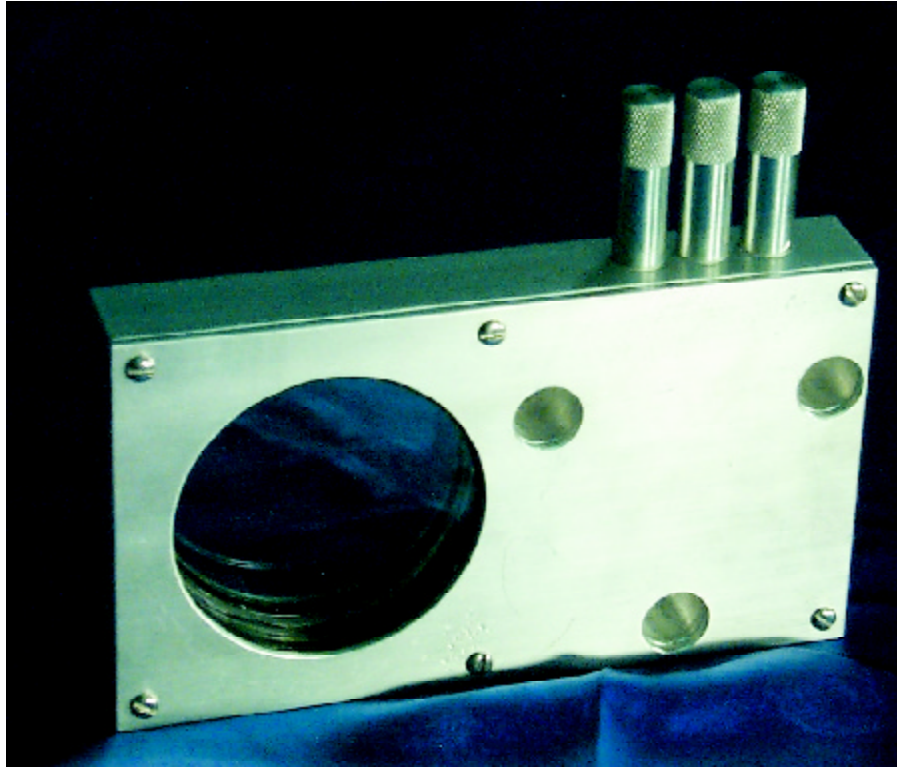

Verifying Calibration with External Cell:

The standard external calibration cell is 0.6 inches thick internally. This is approximately 1/100th of the entire external light path (the distance between the two lenses) for a standard crossbar. Therefore, the display will read 100 times lower than the actual gas in this cell. Place this cell in the center of the light path and observe the PPM reading on the display. The display should read the value imprinted on the calibration cell relative to the crossbar length you are using.

Again, if your OMD varies from calibration by more than \pm 10% within a range of 1 to 100 PPM, it should be examined by a trained technician.

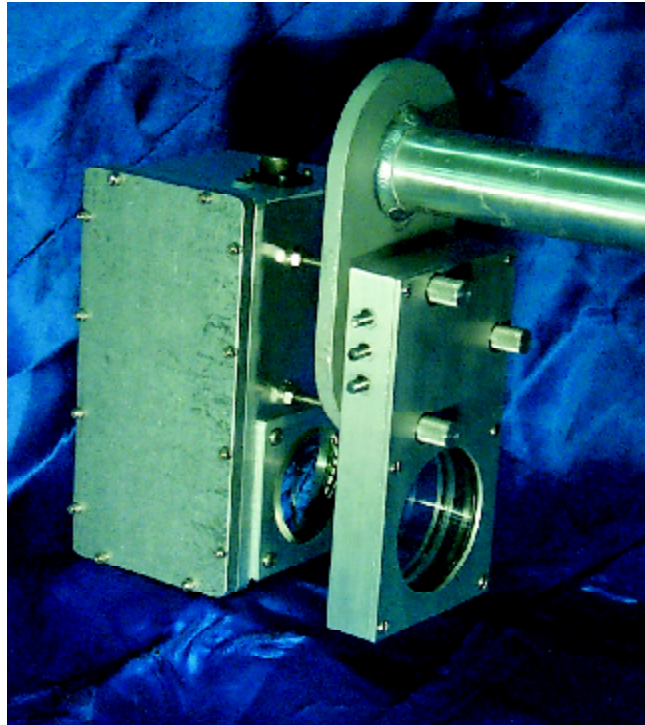

Chapter VI

MAINTENANCE INFORMATION

General

In general the OMD is practically maintenance free. Normally, the only maintenance required is to clean the lenses periodically with a wet cotton rag. It is recommended, however, during winter conditions when sand and salt are used on the roadways that the light bar/receiver assembly is rinsed with water daily to prevent buildup of mineral deposits.

Recommended Spare Parts

There are only two recommended spare parts for the OMD. The first is the IR specific halogen lamp, which is rated to last one to two years. The Heath part number for the lamp is 2510592. The second is a fuse: 7 amp SLO-BLO (3AG), Heath part number 2510569.

TROUBLESHOOTING

<u>PROBLEM</u>	<u>SOLUTION</u>
Light won't turn on:	Check connectors for light source.
Light comes on but "Light Error" alarm occurs:	Clear obstructions from light path. Check light level, if it differs by more than 50, re-align lamp.

<u>PROBLEM</u>	<u>SOLUTION</u>
“Light” alarm occurs:	Clean lenses. If alarm continues, re-align optics.
“Warm-up” alarm occurs:	Turn light off until system warms up.
“Failure” alarm occurs:	Exit sample mode while communicating through RS-232 port.
“Batt Low” alarm occurs:	If it occurs while vehicle engine is off, start engine. If it occurs while engine is running, have your battery and charging system checked by a mechanic.
Water has condensed on the inside of the receiver lens:	The receiver has obtained a leak, return the OMD to the factory for repair.
Water has condensed on the inside of the light assembly lens:	The light assembly has obtained a leak, return the OMD to the factory for repair.

TROUBLESHOOTING

PROBLEM	SOLUTION
Display is blank:	Press and hold contrast down button for approx. 15 seconds or until writing appears on screen. If display is still blank, repeat with contrast up button. If screen is still blank call The Heath Customer Service Department.
Audible alarm not sounding:	Press and hold speaker for 15 seconds. Lower the alarm set point until it's approx. two PPM above PRESENT. Press CALIBRATION TEST button to test alarm. If audible alarm still doesn't work, call The Heath Customer Service Department.

Chapter VII

SERVICE INFORMATION

Warranty and Warranty Repairs

The OMD is warranted to be free from defects in material and workmanship for one (1) year from date of shipment.

The warranty on authorized repairs in the Houston factory service center (FSC) is ninety (90) days materials and thirty (30) days labor. This repair warranty does not extend any other applicable warranties.

Our warranty covers only failures due to defects in materials or workmanship which occur during normal use. It does not cover failure due to damage which occurs in shipment, unless due to improper packing. It does not cover failures which result from accident, misuse, abuse, neglect, mishandling, misapplication, alteration, modification, or service other than at a Heath Consultants warranty repair location.

Heath Consultants' responsibility is expressly limited to repair or replacement of any defective part, provided the product is returned to an authorized warranty repair location, shipped pre-paid, and adequately insured. Return shipping and insurance will be at no charge to the purchaser.

We do not assume liability for indirect or consequential damage or loss of any nature in connection with the use of any Heath Consultants product.

There are no other warranties expressed, implied, or written except as listed above.

SERVICE

The following suggestions will expedite the repair of your instrument:

- Package carefully, using the original shipping carton if available, and return all components.
- Specify your complete shipping and billing addresses.
- Specify the instrument or product name, model number, and serial numbers on all correspondence.
- Include a brief description of the problem you are experiencing and specify the person to be contacted for information.

Customer Assistance and Service Locations

If for any reason assistance is required, technical or otherwise, please contact Heath Customer Service at the following phone number. If it is necessary to ship the OMD for service or repair, you may use the original shipping box and ship the OMD to the following address:

NOTE:

The OMD can be returned only after calling customer service to obtain a Return Authorization tracking number.

*Customer Service Phone 1-800-HEATH-US
(1-800-432-8487)*

CORPORATE HEADQUARTERS

Heath Consultants Incorporated

9030 Monroe Road
Houston, Texas 77061
Phone: (713) 844-1300
Fax: (713) 844-1309
www.heathus.com

MANUFACTURING AND WARRANTY SERVICE FOR
THIS PRODUCT

Heath Consultants Incorporated

9030 Monroe Road
Houston, Texas 77061
Phone: (713) 844-1350
Fax: (713) 844-1309

APPENDIX A

HEATH CONSULTANTS INCORPORATED SURVEY PROCEDURES - MOBILE OMD

PROCEDURES

I. Planning the Survey

A. Specific Survey Requirements

During the initial contact with the company official, it is most important to review survey procedures. If there are any specific variations from standards involved, the consultant must contact his supervisor. **VARIATIONS FROM STANDARDS MUST BE NOTED ON THE FINAL REPORT.**

During the initial contact with the customer, the consultant should, when applicable, arrange to obtain the following data:

1. A map(s), or lists of main and service locations in the area to be surveyed. If maps are used, the daily coverage of the survey should be plotted in a color code to establish each day's coverage. Large-scale maps may be difficult to manage so it is suggested that you attempt to obtain key sheets of the plate maps, or small-scale maps, showing large areas.
2. If your orders indicated that less of the entire system is to be surveyed, find out specifically what areas are to be done.
3. The name and telephone number of the company representative you are to call when you find leakage indication which requires immediate attention (Grade 1).
4. The name of the person who is to receive daily reports.

5. The names and telephone numbers of persons to contact for location of buried telephone and electric cables.
 6. Obtain any information or location of known underground sprinkler and heated sidewalk systems.
 7. Have they received any complaints about odor, etc. from the public?
 8. Discuss and resolve any questions regarding the survey (i.e. classification, reporting, etc.)
- B. Transportation Requirements
The mobile unit will provide transportation for the consultant.
- C. Planning the Route of Survey
To improve overall safety and efficiency, special consideration should be given to heavy traffic areas, peak periods of this traffic and locations of one-way streets. If possible, the heavily traveled streets should be surveyed prior to, or after, peak traffic flow hours.
UNDER NO CIRCUMSTANCES WILL THE UNIT SURVEY AGAINST TRAFFIC: this procedure is unsafe.
- D. Discuss with Your Guide
1. What he knows about the system that will help you.
 2. What you want him to do.
 3. How you want him to do it.
 4. Safety procedures and suggestions.
 5. Use of Plunger Bar.
 6. Precautions for avoiding damage to underground structures.
 7. Seal of test holes if needed.
 8. Instruct him on the proper and safe routing of the vehicle, if he is to have this function.

II. Equipment Requirements

- A. A vehicle for the terrain to be surveyed should be used. It should have good visibility and maneuverability and must be equipped with safety lights.
- B. Combustible Gas Indicator
- C. Plunger Bar
- D. Report Forms
- E. Other - as needed

III. Method of Operation

- A. Maintenance of Instruments

Each OMD utilized for leak detection and evaluation will be operated in accordance with the manufacturers recommended operating instructions and the following maintenance procedures will be performed:

 - 1. The light path should be checked for dirt build-up at the beginning of each day. If necessary clean with a cotton rag, soap and water.
 - 2. The OMD will be periodically “checked” while in use to insure that it is responding to methane gas by pressing the “CALIBRATION/TEST” button.
- B. Calibration of Instrument

The functionality should be periodically “checked” by pressing the “CALIBRATION/TEST” button. If the OMD is suspected to be out of calibration it should be verified with an external calibration cell. If the OMD™ is verified to be out of calibration, it must be re-calibrated.
- C. Survey Procedures

The consultant drives along those areas to be surveyed placing the light path of the OMD just above the soil or pavement surface. While conducting a mobile survey

the consultant should make every effort to place the OMD over available openings. When the detector senses the presence of methane in the sample, an audible alarm sounds and a read-out of the amount of methane detected is indicated on the display. If necessary the consultant can stop and rerun the suspected area to better establish the point(s) of venting. Then plunger bar holes are made to confirm with a combustible gas indicator, the presence of methane in the soil. The leak indication is then centered and classified. The results are recorded and the survey is resumed.

In paved locations, the survey can be conducted by sampling along the curb, or the side of the street, where the main is located. However, in the instance of dual mains, particularly wide streets or divided traffic lanes, a particular street should be traversed in both directions. In unpaved locations, sampling is done as close to the buried structure as possible.

The consultant will use system maps to determine which streets to survey and where the main is in the street. As each successive street is surveyed, it is recorded on the map and color-coded as a record of the daily survey coverage.

D. Survey Coverage

A standard mobile survey includes designated gas mains. It does not include service line inspections. Mains or service lines that are not accessible to the mobile unit, may be inspected as described in the portable flame ionization survey procedures. Example: in areas where vehicles are parked over the main, the consultant would consider using the flame ionization instrument in the portable mode. Often, it is advisable to survey both sides

of the designated streets, particularly where a single main exists, with long services running to the opposite side in a wall-to-wall pavement area. Experience shows that many curb line service leak indications are detected when a mobile unit surveys both sides of the street.

E. Tests of Available Openings

Available openings, as described by the American Society of Mechanical Engineers (ASME), are openings large enough to allow a man to enter (i.e., sewer and telephone manholes, catch basins, vaults, etc.)

F. Report Requirements

Several report forms may be required. The report forms for a particular survey will be specified on the survey orders or by the supervisor.

See the Heath Field Manual for specific instructions for each form specified. All areas surveyed shall be designated by one (1) of the following:

1. Daily Color-coding Map
2. Daily Service Line Listing
3. Daily Street Listing

IV. Classification of Indicated Leakage Areas

(See also Leak Classification section of Heath Field Manual)

Each location where combustible vapors are detected and centered will be classified, in the judgement of the consultant, as a 1(C), 2(B) or 3(A) leak location. (Leak grades based on A.S.M.E. standards.)

1. Grade 1(C) - A leak that represents an existing or probable hazard to persons or property, and requires immediate repair or continuous action until the conditions are no longer hazardous.

2. Grade 2(B) - A leak that is recognized as being non-hazardous at the time of detection but requires scheduled repair locations are completed.
3. Grade 3(A) - A leak that is non-hazardous at the time of detection and can be reasonably expected to remain non-hazardous.

The purpose of classification is to arrange the locations in order of priority to assist the operator in scheduling, pinpointing and repair. THE CLASSIFICATION IS A JUDGEMENT BY THE CONSULTANT BASED ON THE INFORMATION AVAILABLE TO HIM. It in no way indicates the condition of the pipe or the size of the leak in the pipe or the amount of gas leaking on concealed piping.

Any leak indication detected, which, in the judgement of the consultant, requires immediate attention (Grade 1) should be reported by telephone to the designated official when detected unless otherwise instructed by the client. The time the leak is called in must be noted on the leak report.

“Each leakage area which is to be classified, must first be evaluated to determine the extent of gas migration. Bar holes must be placed and tested with CGI in all directions until zero readings are obtained. When gas has entered substructures, available openings to affected substructures must be tested in all directions along that system until zero readings are obtained.”

V. Factors Which Affect Gas Migration

The success of surface survey greatly depends on the migration of gas through the soil and atmosphere. The technician must consider these factors and their effects throughout the survey.

A. Moisture Content of the Soil

The higher the moisture content, the more difficult it becomes for gas to vent and thus to be picked up by the instrument. During heavy rains, or immediately after, it may be necessary to stop the survey, or move to an area where venting conditions are satisfactory due to a change in soil type or elevated gas pressure. Whenever venting conditions are questionable, re-survey one or more known leak locations that were low volume when first detected to see if venting is adequate.

B. Soil Type

Heavy clay type soils and soils with hardpans tend to limit and restrict the venting process. Heavy moisture in this type of soil tends to further restrict venting.

C. Effect of Paving

Continuous paving certainly reduces venting of gas from the soil. However, most paving includes expansion joints and most asphalt paving has cracks, depending on its age, and gas will vent at these locations. Freshly paved concrete and asphalt areas provide very poor and limited venting points as opposed to older streets. Should the main be, for example, ten feet into the street from the curb, with the street having a new concrete cover, the curb line would provide the most desirable sampling point. A very compact soil with a gravel type cover, for example, or a heavily traveled alley, will also restrict venting.

D. Gas Pressure

Low-pressure gas systems generally will vent much more slowly and poorly than higher pressure systems. High soil moisture content can minimize the point that a survey in low-pressure areas is not practical. In most instances, this is of a temporary nature and the survey can be continued by moving to a high-pressure area in the system. It is important that the technician know in what pressure areas he will be working.

E. Snow Cover

The effect of snow cover on gas venting conditions is related to the length of time it has been on the ground, its moisture content and temperature variations. Newly fallen snow with low moisture content is loosely compacted and tends not to inhibit venting. As moisture content increases, greater compaction occurs, which tends to restrict venting. If the snow has high moisture content, or rain has occurred since it fell, followed by subfreezing conditions, venting may be considerably reduced. Disturbing the surface of the snow with the probe will often release gas trapped in the snow.

F. Frozen Soil

The moisture content of the soil at the time it freezes has a considerable effect on the venting conditions of frozen ground.

The higher the moisture content, the less porous the frozen ground is. However, as the ground freezes, it tends to develop a well-defined system of cracks that will al-

low gas to vent rather well. These cracks are subject to filling with water if there is thawing or rain which temporarily reduces venting.

The most ideal condition for venting during a winter survey is sustained weather below freezing with clear, dry streets. The presence of frozen ground will cause leak locations to spread further in the soil, which often results in gas seeping into more available openings. As a result, your sampling pattern should include as many such openings as possible.

G. Wind Velocity

Wind velocity has, generally, more influence on the ability to perform a successful survey than any other environment factor. Ideal conditions are, of course, at such times as the wind velocity is zero M.P.H. (miles per hour). Very heavy winds, on the other hand, dilute the sample and disperse the sample in the air. In several parts of the country, the problem of prevailing winds can be nullified by starting the survey earlier in the morning and ending earlier in the afternoon. If on a survey where the environmental conditions are hindering his ability to do a good job, the technician should contact his immediate supervisor.

H. Location of Underground Structures

The consultant must know the general location of the gas main and other subsurface structures. Gas will tend to follow water lines and other substructures, vent near valves or water meter boxes, etc. In general, the best sample points are those cracks in the pavement nearest the main and curb line and any vertical structures such as risers, building walls, poles, sign posts, etc.

In heavily paved areas, special care should be taken to sample as many venting locations as possible, including available openings.

HEATH CONSULTANTS INCORPORATED OPERATING STANDARDS - MOBILE OMD™ SURVEY

GENERAL SPECIFICATIONS

I. Purpose of Survey

The purpose of the survey is to inspect any portion of a gas system, which can be driven over, or adjacent to, to detect, classify and report leakage locations that are venting to the atmosphere.

II. Scope

A. Portion of System to be Inspected

The mobile survey is used in any area where the vehicle can be driven in such a manner as to place the light path of the OMD within the plume of methane that is venting from the ground.

B. What is Inspected

Mobile survey provides coverage of mains, associated valves, regulators and drips, the service taps at the main and that portion of the service line located in or near the street, alley or area where the survey vehicle can be driven.

III. Personnel Required

The survey is conducted by a one or two-person team.

IV. Equipment Required

A. A vehicle containing the following:

1. OMD
2. Plunger Bar
3. Combustible Gas Indicator
4. Report Forms

V. Transportation Requirements

Any vehicle designed for the terrain to be covered.

VI. Method of Operation

A. Maintenance of Instruments

Each instrument utilized for leak detection and evaluation will be operated in accordance with the manufacturers recommended operating instructions and the following maintenance procedures will be performed:

1. The light path should be checked for dirt build-up at the beginning of each day. If necessary clean with a cotton rag, soap and water.
2. The instrument will be periodically “checked” while in use to insure that it is responding to methane gas by pressing the “CALIBRATION/TEST” button.

B. Calibration of Instrument

The calibration should be periodically “checked” by pressing the “CALIBRATION/TEST” button. If the OMD is suspected to be out of calibration it should be verified with an external calibration cell. If the OMD is verified to be out of calibration it must be re-calibrated.

C. Survey Procedures (Regular Mobile Survey)

The survey is conducted by driving the unit along those areas to be surveyed and passing the light path over the most logical venting locations for gas leaking from below ground. The survey is conducted at a speed slow enough to allow an adequate sample to pass through the light path, giving consideration to the location of the gas facility and any adverse conditions that might exist.

In most paved locations the survey can be conducted by driving along the curb or the side of the street where the main is located. However, in the instance of dual mains, particularly wide streets or divided traffic lanes, a particular street may be traversed in both directions. In unpaved locations, sampling is done as close to the buried structure as possible.

When the detector senses the presence of methane in the light path, an audible alarm sounds and a read-out of the amount of methane detected is indicated on the display. The consultant will stop the unit and make plunger bar holes to confirm, with a combustible gas indicator, the presence of a combustible in the soil and then center and classify the leakage indication. Results are then recorded and the survey is resumed.

The client should supply accurate maps to the consultant. These will be used to determine which streets to survey and where the mains are located.

As each successive street is surveyed, coverage is recorded on the map and color coded as a record of the daily street coverage.

D. Survey Procedures (Patrol Type Survey)

The patrol type survey is conducted in the same manner as the standard survey, with the exception that the speed a vehicle travels can be much higher. Once an indication is detected, the same confirmation, classification and report procedures, as in the standard survey, are used.

The use of a patrol survey, during severe conditions such as heavy frost, is a means of detecting large volume leaks that are venting to the atmosphere. The survey should not be considered a thorough survey, but only as a supplement to the standard survey program.

VII. Centering of Leakage Detection

Whenever combustible vapors are detected in the soil or substructure atmospheres, additional tests will be conducted to determine the extent of the spread of the gas. The pattern of spread, as well as the relative volume of gas throughout the spread, will be observed to establish the logical source of the leakage indication.

VIII. Classification of Indicated Leakage Areas

Each location where combustible vapors are detected and centered will be evaluated and classified, in the opinion of the consultant, as a 1(C), 2(B), or 3(A) leak location. (Leak grades based on A.S.M.E. standards.)

1. Grade 1(C) - A leak that represents an existing or probable hazard to persons or property, and requires immediate repair or continuous action until the conditions are no longer hazardous.
2. Grade 2(B) - A leak that is recognized as being non-hazardous at the time of detection but requires scheduled repair based on probable future hazard. Schedule for repair after Grade 2 locations are completed.
3. Grade 3(A) - A leak that is non-hazardous at the time of detection and can be reasonably expected to remain non-hazardous.

The purpose of classification is to arrange the locations in order of priority to assist the operator in scheduling, pinpointing and repair.

THE CLASSIFICATION IS A JUDGEMENT BY THE CONSULTANT BASED ON THE INFORMATION AVAILABLE TO HIM. It in no way indicates the condition of the pipe or the size of the leak in the pipe or the amount of gas leaking on concealed piping.

IX. Production per Day

Coverage per day will vary due to local conditions and leak indication frequency.

X. Report Requirements

A. Any leak indication detected, which in the judgement of the consultant requires immediate attention (Grade 1), will be reported by telephone to the designated official when detected, unless otherwise instructed by the client. The time the leak is detected will be noted on the leak report.

B. Coverage Maps

When available, maps indicating daily coverage are prepared and turned in to the official in charge of the survey at the completion of the survey, and a release form obtained to confirm receipt. These maps are stamped, signed and dated as a permanent record of the survey.

C. Street Listings

Where maps are not available, lists are prepared detailing the streets and/or specific lines surveyed. These lists are bound into the final report and returned to the Gas Company upon completion of the survey.

D. Leak Location Report

Leak reports indicating the leak locations detected each day will be prepared in triplicate for each leak location investigated by the consultant. The original is returned to the client in the final report of the survey. The duplicate is given to the client at the end of each survey day and the consultant as a safeguard retains the triplicate until the client has received the final report.

APPENDIX B

DRAWINGS

- 1 INSTALLATION ISOMETRIC**
- 2 INSTALLATION ERROR # 1**
- 3 WIRING DIAGRAM 1 OF 2**
- 4 WIRING DIAGRAM 2 OF 2**

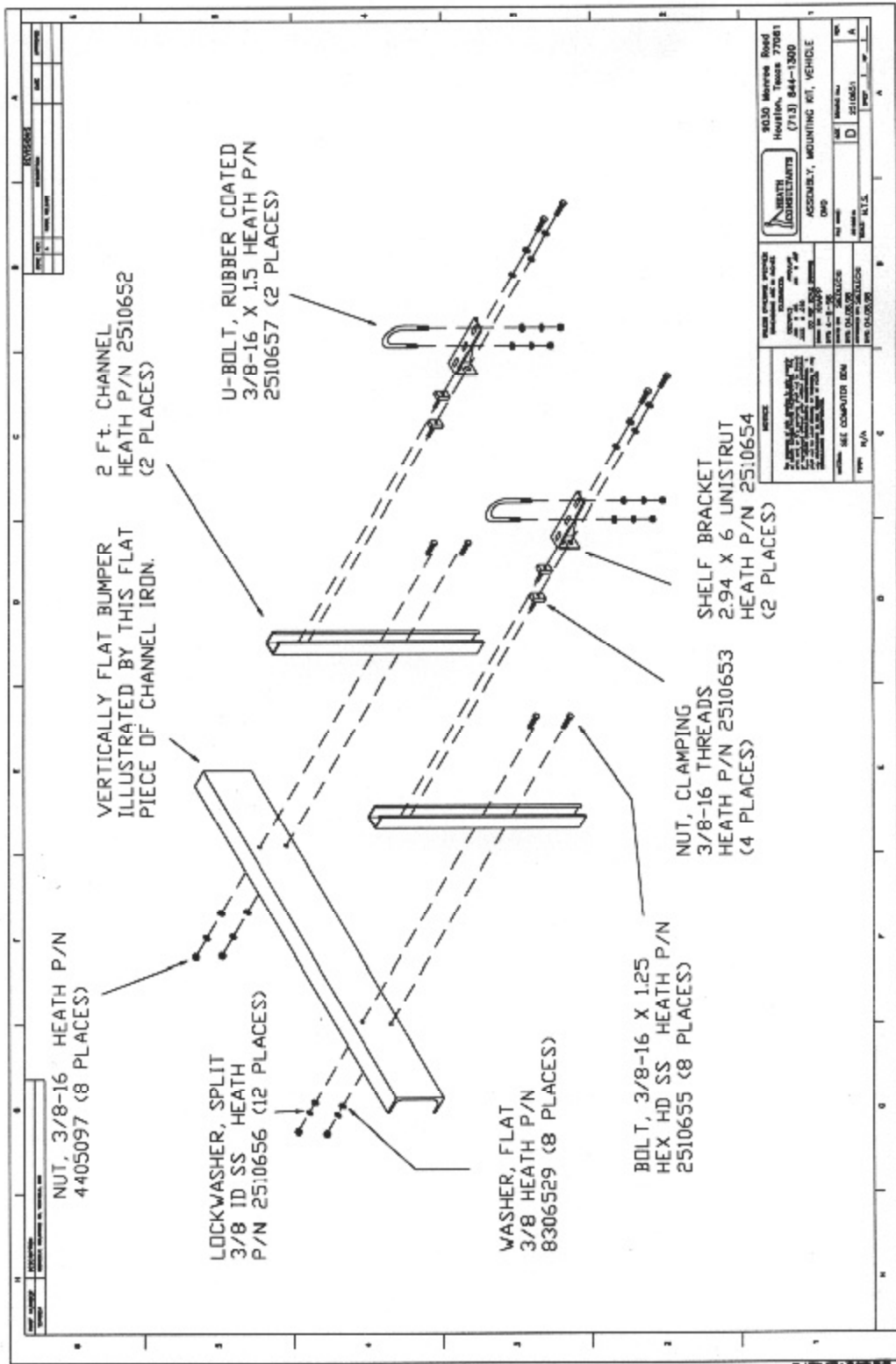

REVISIONS DATE: _____ BY: _____ REASON: _____	
DESCRIPTION PART NAME: _____ PART NUMBER: _____ QUANTITY: _____	
MANUFACTURING INFORMATION DRAWING NO.: _____ REV. NO.: _____ DATE: _____ BY: _____ CHECKED BY: _____ APPROVED BY: _____	
COMPANY INFORMATION COMPANY: HEALTH INDUSTRIES ADDRESS: 9030 Meyers Road Houston, Texas 77061 PHONE: (713) 844-1300	
ASSEMBLY INFORMATION ASSEMBLY: MOUNTING KIT, VEHICLE PART NO.: _____ QUANTITY: _____ DATE: _____ BY: _____ CHECKED BY: _____ APPROVED BY: _____	
OTHER INFORMATION SEE COMPUTER IDN TYPE: N/A	

REV	DATE	BY	APPVED

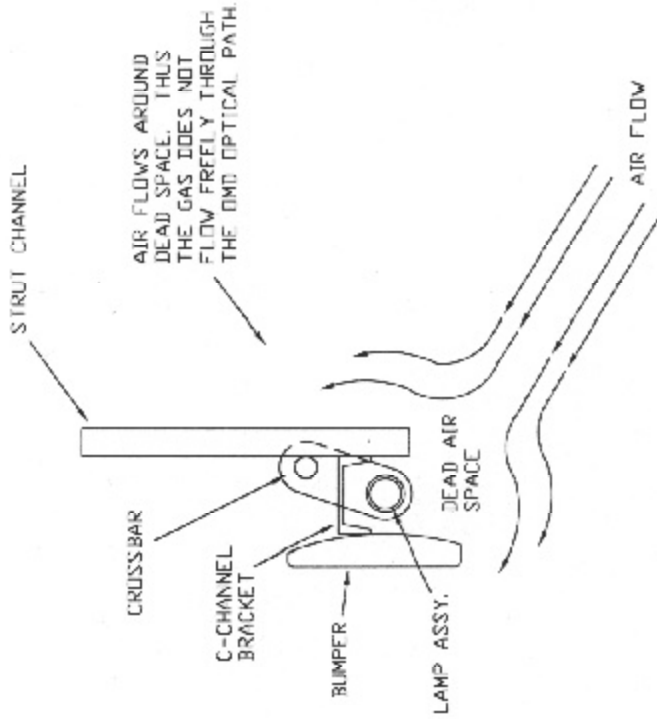

THIS IS AN EXAMPLE OF HOW NOT TO INSTALL THE DMD ON THE FRONT OF A TRUCK. THE BRACKETS BELOW THE CROSSBAR HAVE CREATED A DEAD SPACE THAT PREVENTS THE AIR FROM FLOWING FREELY ACROSS THE OPTICAL PATH.

<small> LINDSAY ENGINE & MACHINE CONSULTANTS 2111 W. 10th St. S.W. OKLAHOMA CITY, OKLA. 73109 (405) 521-1111 </small>		INSTALLATION	
		NO NO #1. DMD	
<small> DRAWN BY CHECKED BY DATE </small>	<small> TITLE PROJECT NO. </small>	<small> SCALE NONE </small>	<small> SHEET NO. 1 OF 1 </small>
<small> LINDSAY ENGINE & MACHINE CONSULTANTS 2111 W. 10th St. S.W. OKLAHOMA CITY, OKLA. 73109 (405) 521-1111 </small>			<small> SHEET 1 OF 1 </small>

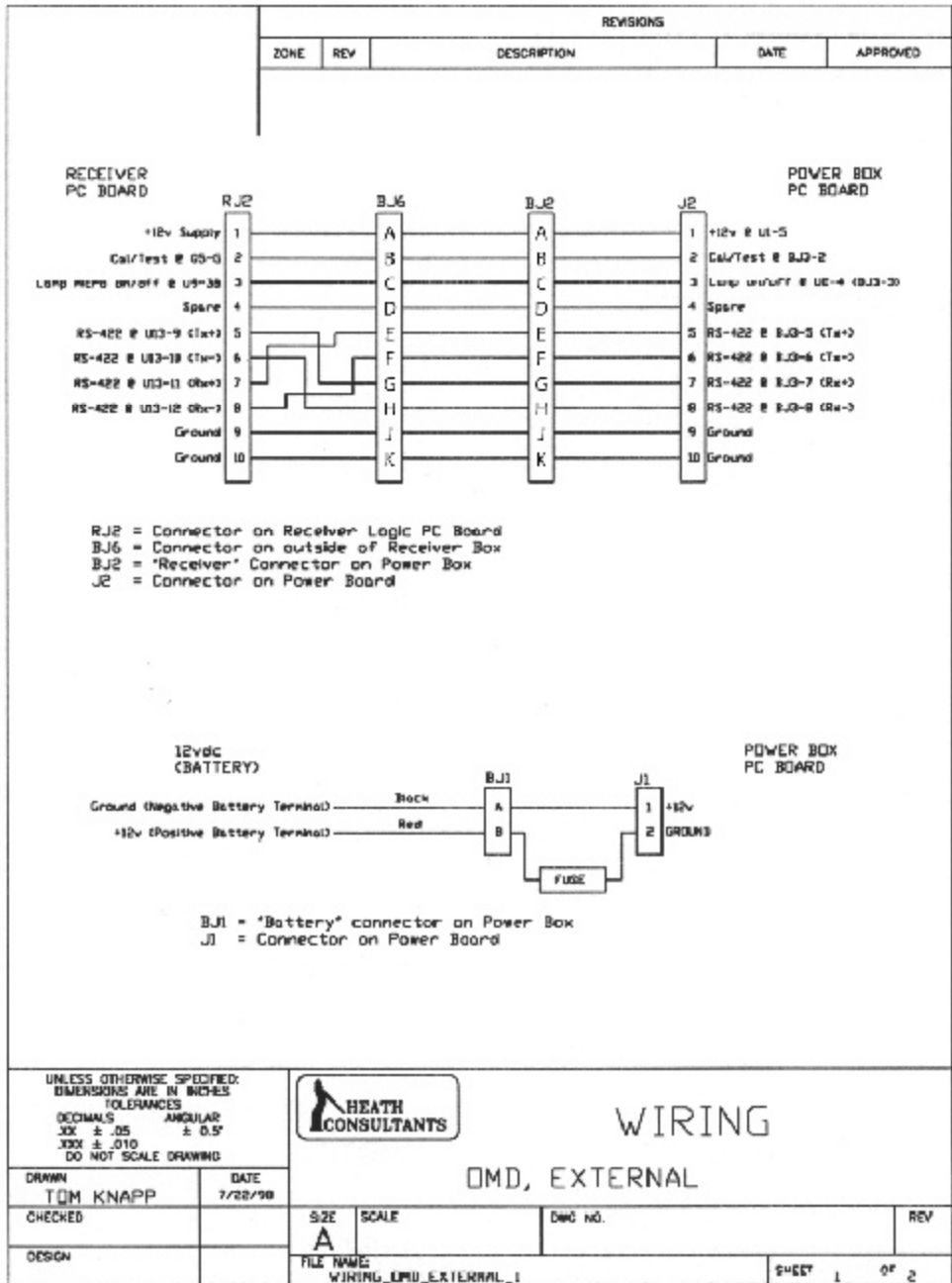

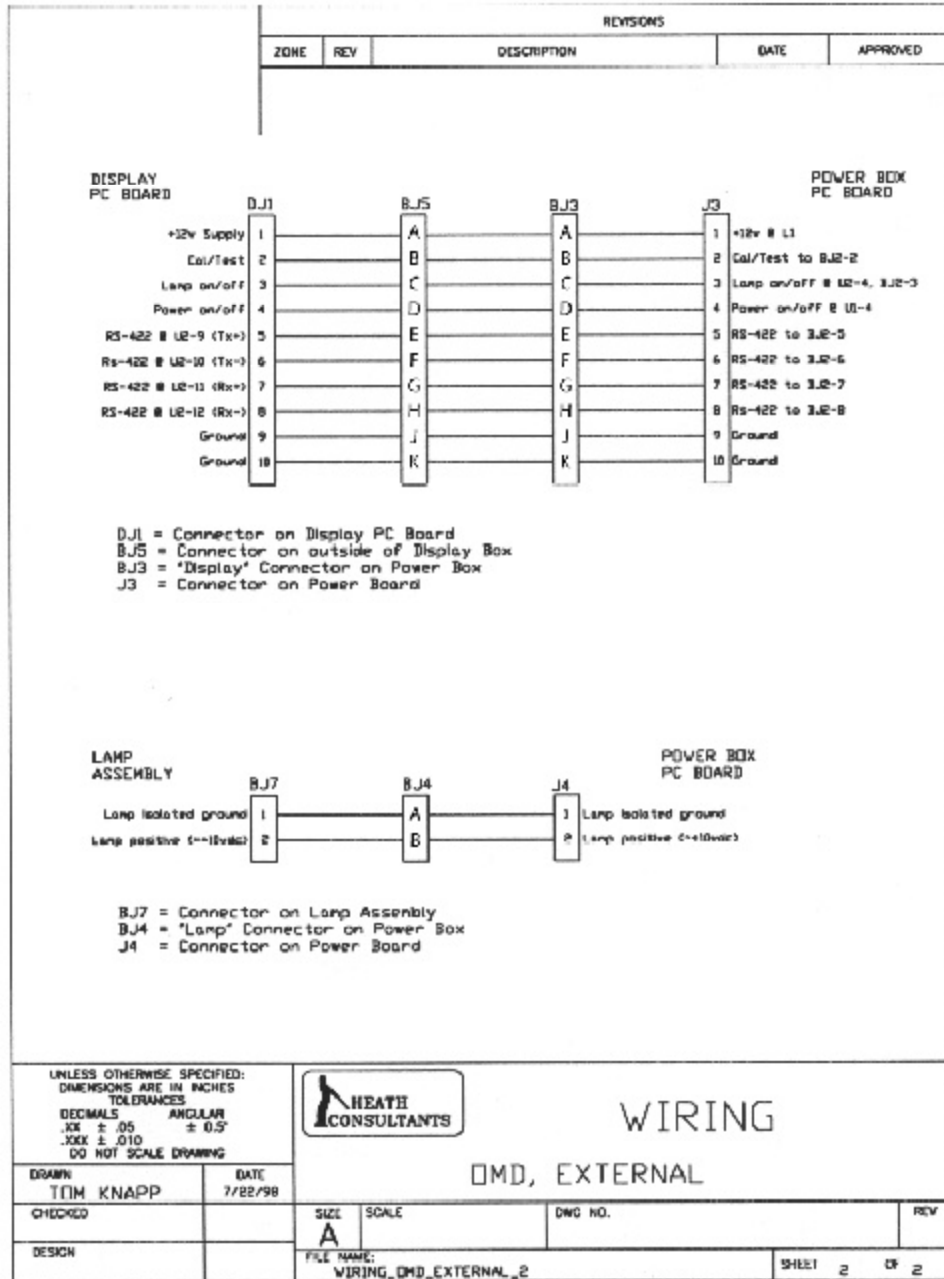

USING ADOBE ACROBAT READER

The OMD WINCAL and User Manuals are included on the OMD WINCAL CD-ROM.

Both manuals are in the portable document format (.pdf) used with the Adobe® Acrobat® Reader Software, also included on the OMD WINCAL CD-ROM.

To open the manuals:

If you have Adobe Acrobat Reader 3.0 or later, simply double click either file: **wincal.pdf** or **user.pdf**.

If you do not have Adobe Acrobat Reader 3.0 or later, you must install Adobe Acrobat Reader 6.0 which is included on the WINCAL CD ROM.

1. Insert the CD-ROM.
2. Double click on my computer.
3. Double click on WINCALCD drive.
4. Select the **Manuals** folder.
5. Double click on the executable file: **adbeRdr60_enu_full.exe**.
6. Follow the directions given by the Install Wizard.
7. Once you have installed Adobe Acrobat Reader, double click either on file: **wincal.pdf** or **user.pdf**.

If you have any problems with this CD-ROM or any of its files, contact Heath Consultants Incorporated at 800-432-8487 or CustomerService@heathus.com.



Declaration of Conformity

Manufacture's Name: Heath Consultants
Manufacture's Address: 9030 Monroe Road
Houston, TX 77061

Model: Optical Methane Detector

Has been demonstrated to be in compliance with the European EMC directive (89/336/EEC), FCC 47 CFR, Part 15, Subpart B, Class A, and ANSI C63.4, and is in accordance with the following standards:

EN 61326-1		
Radiated Emissions	Class A	April 25, 2005
FCC 47 CFR Part 15	Class A	April 25, 2005
ANSI C63.4	Class A	April 25, 2005
EN 61000-4-2	4/8kV	April 26, 2005
EN 61000-4-3	10V/m	April 27, 2005
EN 61000-4-4	10V/m	April 26, 2005
EN 61000-4-5	10V/m	April 26, 2005
EN 61000-4-6	10V/m	April 26, 2005
EMC 72/245/EEC		April 28, 2005

Date of Issue: May 16, 2005

Signed by: _____ (On File)
Graham Midgley
Heath Consultants CEO

