

Diffusion type Gas Detector

Model KD-12

Instruction Manual

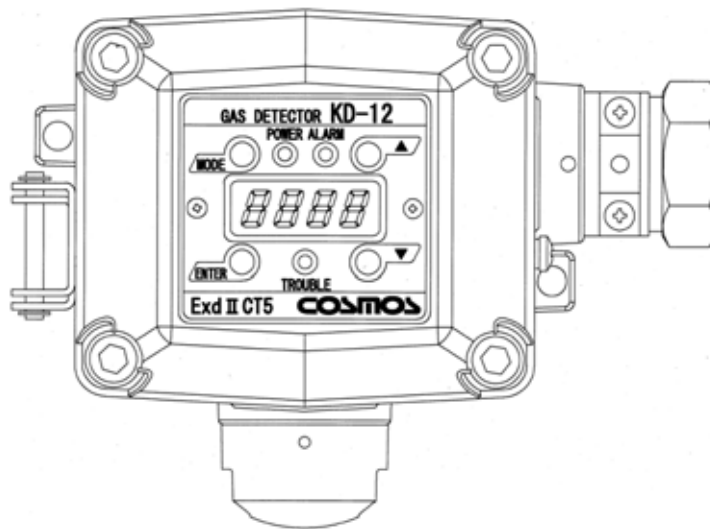

- Keep this instruction manual where it is readily accessible.
- Thoroughly read this instruction manual before using the equipment so it can be used safely and correctly.
- This manual provides information concerning standard specifications. If the specifications of your model are nonstandard, refer to the delivery specifications.

 **New Cosmos Electric Co., Ltd.**

Instruction Manual No.
GAE-029-01
May 2010

• **Nomenclature**

See pages 4 to 6.

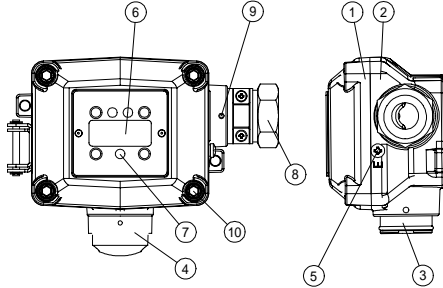

• **Replacement of Sensor Unit**

See pages 28 and 29.

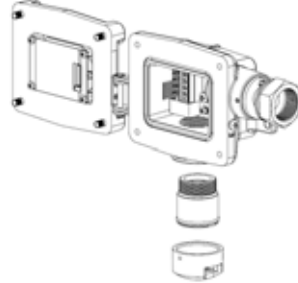

• **Wiring and Connecting Methods**

See pages 11 to 14.

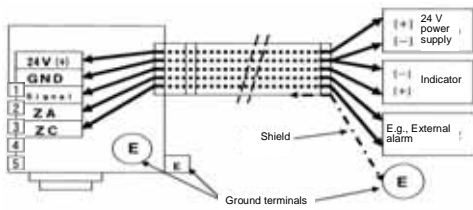

• **Display and Operation in Each Mode**

See page 17.

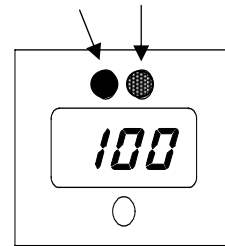

• **Maintenance Check and Operation Methods**

See pages 19 to 27.

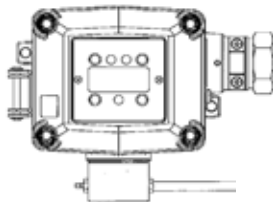

• **Troubleshooting**

See page 30.

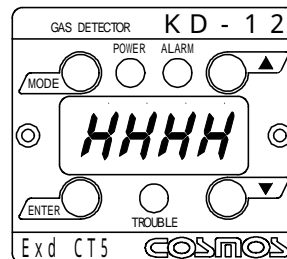

Table of Contents



1. Introduction.....	1
2. Precautions.....	2
3. Contents of Package	3
4. External Dimensions and Nomenclature.....	4
4-1. Main Unit	4
4-2. Display and Control Blocks.....	5
4-3. Terminal Block	6
5. Installation	7
5-1. Installation Method	7
5-2. Examples of Installation Positions	9
5-3. Mounting of Optional items.....	10
6. Wiring Method	11
6-1. Wiring Work.....	11
6-2. Wiring and Connection	12
7. Precautions before Use	15
● In Case of Gas Leakage	15
8. Display at Start-up (Initial Delay)	16
9. Display and Operation in Each Mode	17
10. Trouble Alarm	18
11. Maintenance Check and Operation Method	19
11-1. Daily Inspection and Periodical Inspection	19
11-2. Preparing Calibration Gas	20
11-3. Calibration Method	22
● Maintenance Mode.....	22
● Zero Adjustment.....	23
● Span Rough Adjustment.....	25
● Full-scale and Alarm Set Value Display	26
● Test Mode.....	27
11-4. Replacement of Sensor Unit.....	28
12. Troubleshooting	30
13. Specifications.....	31
14. Warranty	32
15. Life Expectancy	33
16. Detection Principle.....	34
16-1 . Catalytic Combustion.....	34
16-2 . Hot Wire Semiconductor.....	34
16-3 . Thermal Conductivity.....	34
17. Glossary.....	35

1. Introduction

- Thank you for purchasing the KD-12 Diffusion type Gas Detector.
- In order to ensure the correct and safe operation of this product, be sure to read this manual before use.
- This product detects various types of gas including combustible gas. The product detects gas leakage at an early stage in industrial facilities (e.g., gas production plants and depots, chemical plants, paint factories, and power plants), and outputs the gas concentration value in analog signal form while displaying the gas concentration value.
If the gas concentration reaches a preset alarm level, the red ALARM indicator will flash and turn ON an external contact output, thus helping to prevent disasters such as explosion accidents and fires.
- Select from KD-12A, KD-12B and KD-12C models, each of which incorporates a gas sensor, according to the required specifications. The detection principle for the gas sensor differs for these models.
- Maintenance and inspection are indispensable to the reliable performance of the Gas Detection/Alarm System. Be sure to perform the maintenance checks described in this manual.

Explanation of Symbols

The following symbols are used to indicate and classify precautions in this manual.

 DANGER	Indicates information that, if not heeded, is likely to result in death or serious injury.
 WARNING	Indicates information that, if not heeded, could possibly result in death or serious injury.
 CAUTION	Indicates information that, if not heeded, could result in minor injury, or damage to the product.
MEMO	Indicates advice on handling the product.

2. Precautions

- Read this manual completely and be sure you understand the information provided herein before attempting to use the product.
- Abide by all applicable laws and regulations when using this product.



WARNING

- Be sure to ground the product to prevent electric shocks.
- If there is a gas leak alarm, take the necessary measures in accordance with your company's regulations.



CAUTION

- Licensed members should implement all necessary work for the product including wiring and installation in accordance with all applicable laws and regulations.
- Do not disassemble the product or modify the construction or electric circuits of the product. Otherwise, the explosion-proof construction of the product may be adversely affected.
- Do not install the product in places or near places where silicone sealant or gas is used. Otherwise, the performance of the product may be adversely affected.
- Do not use the Detector continuously over a long period of time in an environment that contains organic solvents, such as aromatic hydrocarbons and halogen hydrocarbons.
- Be sure to provide a protective cover (optional) if the product is installed outdoors.
- Use the product in accordance with applicable laws and regulations.

3. Contents of Package

- The product is provided with the following items. Make sure that none of these items is missing.
- Although the product is packed and shipped with the utmost care, contact your New Cosmos representative if there should be any damage or missing items.

Accessories	Optional items
Detector head Accessory set (see note 1) 12- and 13-mm-dia. pressure-proof packings: 1 each Two 11-mm-dia. washers One C-clamp Two M5 screws Hexagon wrench (nominal dia. 2 and 4): 1 each (see note 2) Instruction Manual (see note 2) MJ-1 Magnetic Stick (see note 2)	Protective cover (see note 3) Horizontal type: KW-41 Vertical type: KW-42 PB-1 2B Pole Mounting Bracket (see note 3) SK-1 Sensor Replacement Jig (see note 3) GCP-09 Calibration Cap (see note 3) Z-001K Gas Calibration Kit 2 bulb hand pump Capillary for 2 bulb hand pump

- Note: 1. The standard product incorporates a built-in pressure-proof packing (12.5-mm dia.), washer (12-mm dia.), and B-clamp.
2. A hexagon wrench, Instruction Manual, and MJ-1 Magnetic Stick are provided for each order.
3. The optional items are for use only by the KD-12.

WARNING

- Do not use the magnetic stick for any purposes other than the operation of this product.
- Keep in mind that when the magnetic stick attracts magnetic objects, tools, iron pieces, etc., your hands may become pinched and injured.
- Do not touch the magnet if you are allergic to metal, otherwise your skin may become chapped or reddened.
- Generally speaking, magnets break easily and the corrosion of the magnet progresses from the fracture location. Fragments of the magnet may also get in your eyes or injure your skin.
- The components of the magnetic stick may melt into water. Do not drink water exposed to the magnetic stick.
- Keep the magnetic stick away from electronic medical devices, such as cardiac pacemakers, or the magnetic stick may obstruct the normal operation of the device.

CAUTION

- Keep the magnetic stick away from magnetic tapes, floppy disks, and prepaid cards. Otherwise, they may become magnetized and the information that they hold may be lost.
- Keep the magnetic stick away from high-precision devices, such as personal computers and watches. Otherwise, they may malfunction.

4. External Dimensions and Nomenclature

4-1. Main Unit

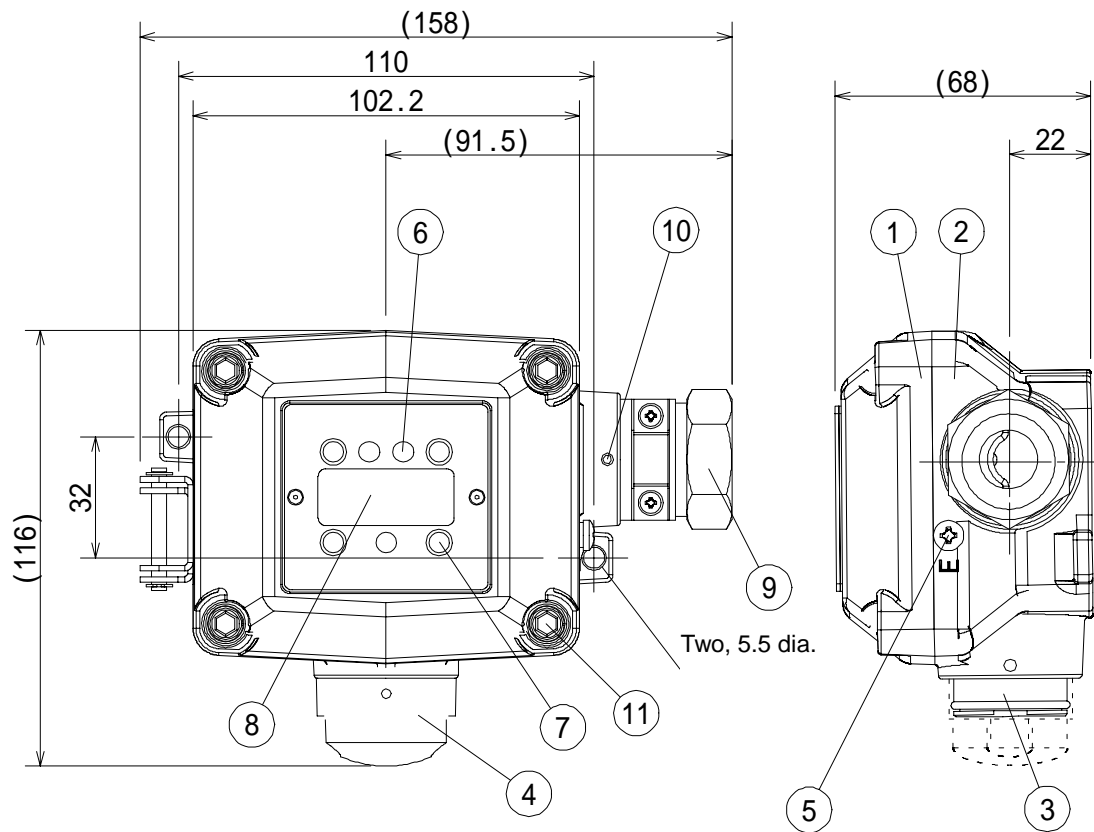

Number	Name	Description
1	Casing cover	
2	Casing	
3	Sensor unit	Incorporates a gas sensor.
4	Sensor guard	Protects the sensor unit.
5	Ground terminal	Used when grounding the frame.
6	State display indicator	Indicates the power supply state (green), alarm state (red), and trouble state (yellow).
7	Control block	Insert the magnetic stick to control or set the product.
8	Display block	Displays the gas concentration and set values.
9	Cable gland	Used to secure the cable. Compatible screw: G3/4.
10	Bolt with hexagon socket	Used for securing the cable gland. Use a hexagon wrench with a nominal diameter of 2 mm.
11	Bolt with hexagon socket	Used for securing the casing cover. Use a hexagon wrench with a nominal diameter of 4 mm.

4-2. Display and Control Blocks

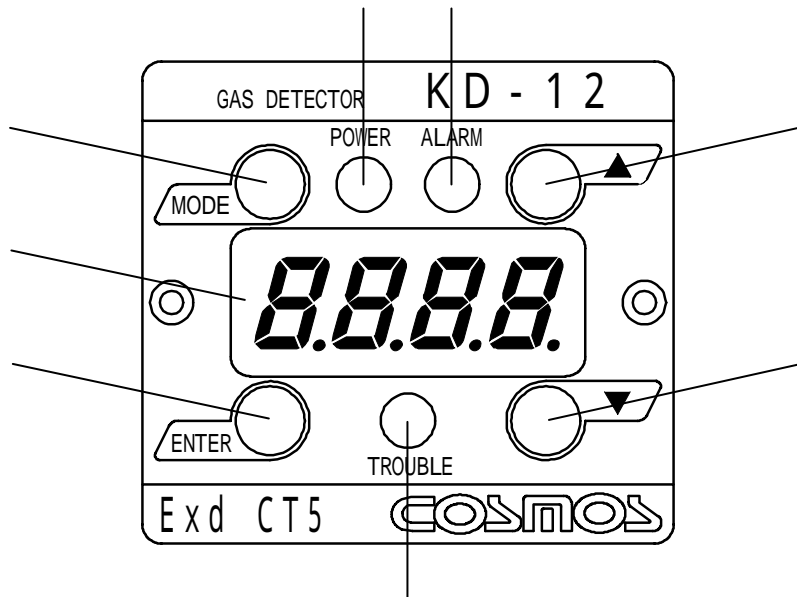

Magnetic switches (Insert the magnetic stick to operate the magnetic switches.)		
Number	Name	Description
1	MODE switch	Makes adjustments and settings or cancels the operation of the product.
2	ENTER switch	Enters settings or completes the control of the product.
3	UP switch	Makes adjustments and settings or increases set values and other values.
4	DOWN switch	Decreases set values and other values.

Number	Name	Description
5	Display block	Displays the concentration of gas and set values.

State display indicator		
Number	Name	Description
6	POWER indicator	A green lamp to display the power supply state.
7	ALARM indicator	A red lamp to display the alarm state.
8	TROUBLE indicator	A yellow lamp to display the trouble state.

4-3. Terminal Block

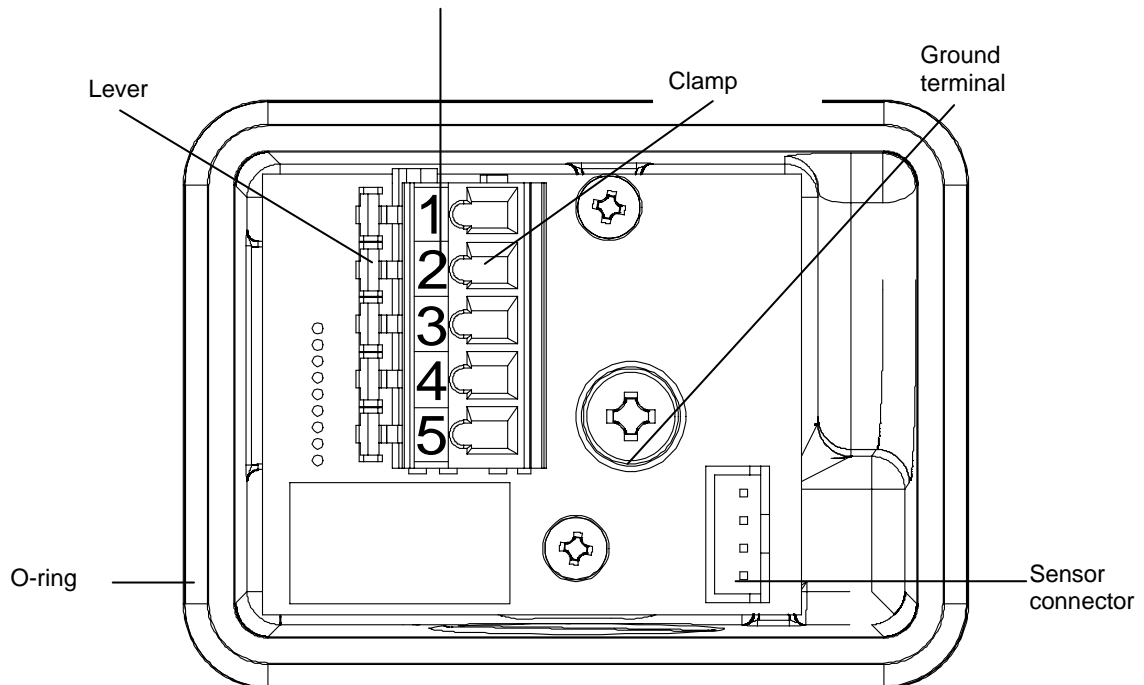
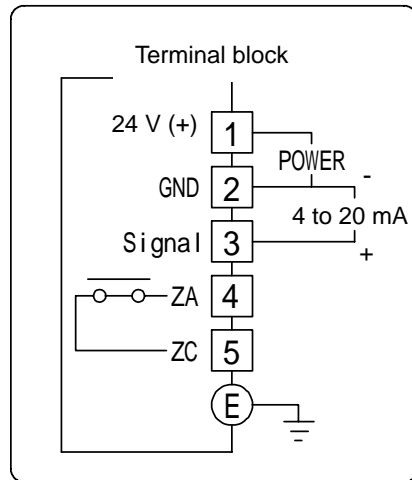

Number	Name	Description
1	24 V (+)	Power supply voltage (positive)
2	GND	Power supply voltage and analog signal (negative) common
3	Signal	4 to 20 mA analog signal
4	ZA	External contact
5	ZC	
E	Ground terminal	Used to ground the frame.

5. Installation

5-1. Installation Method



CAUTION

- Be careful not to damage the gas detector when installing it. Otherwise, the explosion-proof performance of the gas detector will be lost.
- Do not install the product in the following places.
 - Places where the ambient temperature exceeds the operating temperature range (-10°C to 50°C).
 - Places where condensation occurs.
 - Places where water is directly sprayed.
 - Places subject to corrosive gas.
 - Places close to equipment that generates high frequencies or a magnetic field.
 - Places where silicone sealant is used or likely to be used.
 - Places where silicone gas is used or likely to be used.
- Install the gas detector in places where it can be maintained and inspected with ease.
- Install the gas detector in places free from vibration.
- Install the gas detector in places free from sudden temperature changes.
- Keep the gas detector free from impacts.
- When installing the gas detector outdoors, be sure to install the protective cover (optional).
- The installing height of the gas detector has an important relation to the specific gravity of the target gas to be detected. Install the gas detector in accordance with required regulations.

• Installing Height

Type of gas	Installing height	Remarks
Gas heavier than air (Example: LPG)	A maximum of 10 cm above the floor. (Height to the sensor guard tip)	Keep a space of approximately 7 cm from the sensor guard tip for ease of maintenance and inspection.
Gas almost the same as air in specific gravity (Example: Carbon monoxide)	75 to 150 cm above the floor. (Height to the sensor guard tip)	Decide the height by considering the specific gravity and mounting environment.
Gas lighter than air (Example: City gas and hydrogen)	Near the ceiling	Decide the height by considering arrangements for ease of maintenance (e.g., a scaffold).

- Mount the main unit to the wall with the M5 screws that are provided with the product. Be sure to install the protective cover (optional) when mounting the main unit outdoors. Mount the main unit with a 2B pole mounting bracket (optional) when mounting the main unit to a 2B pole. Refer to 5-3 Mounting of Options for details of optional products.

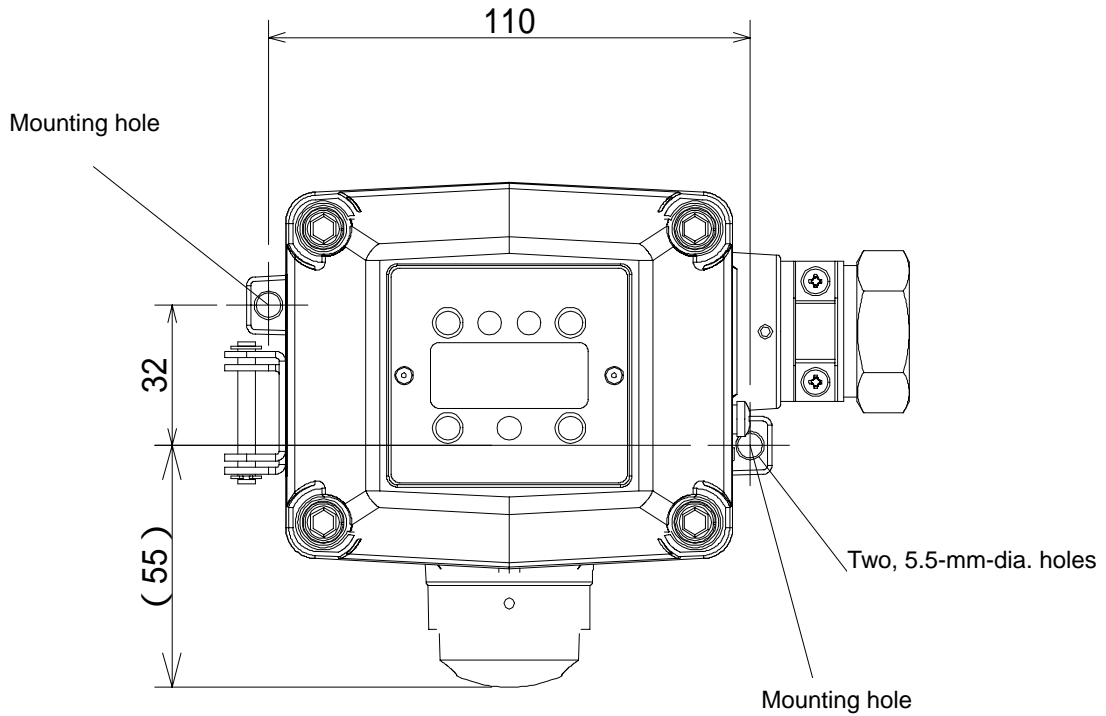

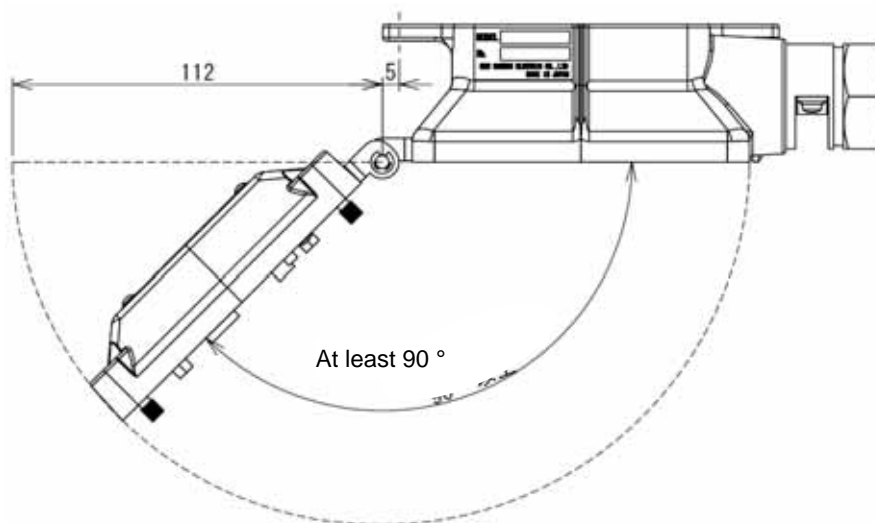

- The casing cover of the Detector must be opened to connect the wiring or replace the sensor unit. When installing the gas detector, provide sufficient space to enable the casing cover to be opened to at least 90°.



5-2. Examples of Installation Positions

- Install the product in places where gas easily accumulates.

 Places where gas easily accumulates.

 Gas detector

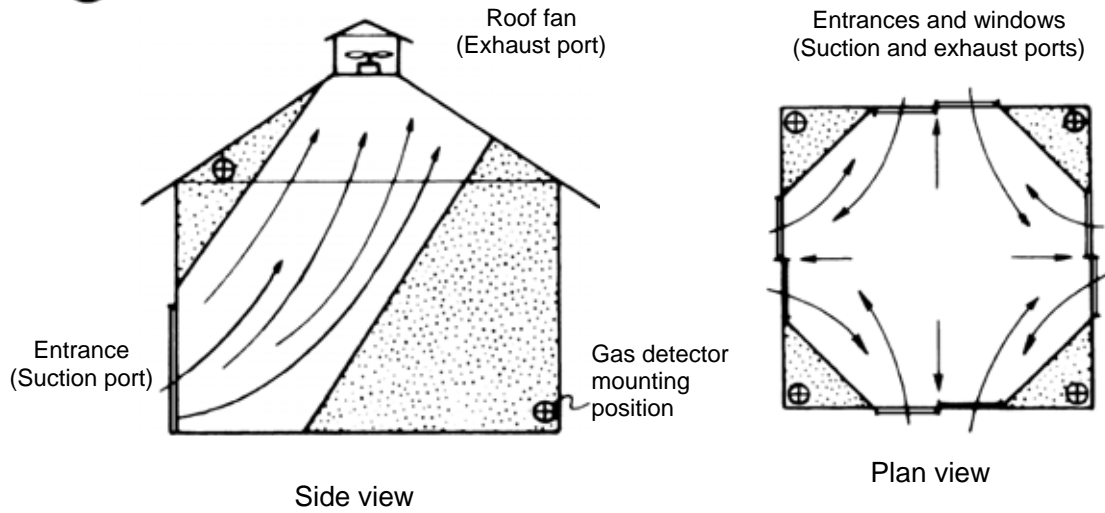

Example of Installation Position

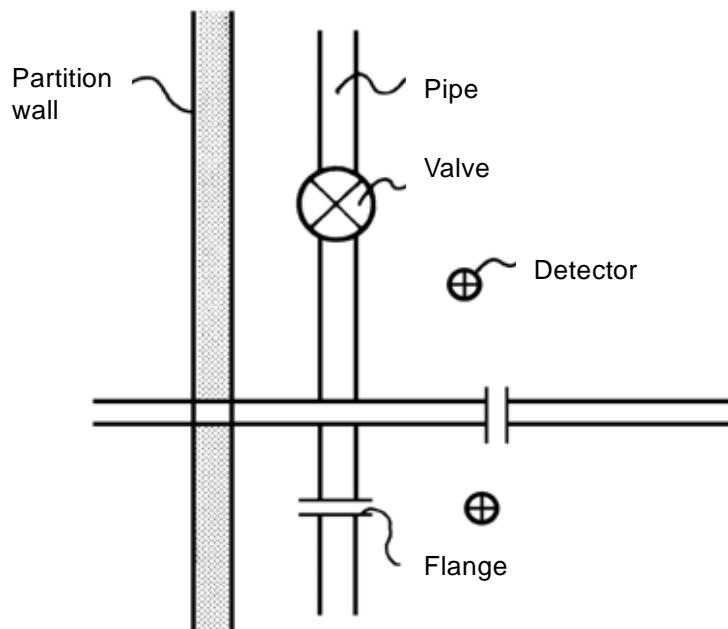

Example of Outdoor Installation Position

5-3. Mounting of Optional items

- Protective Cover

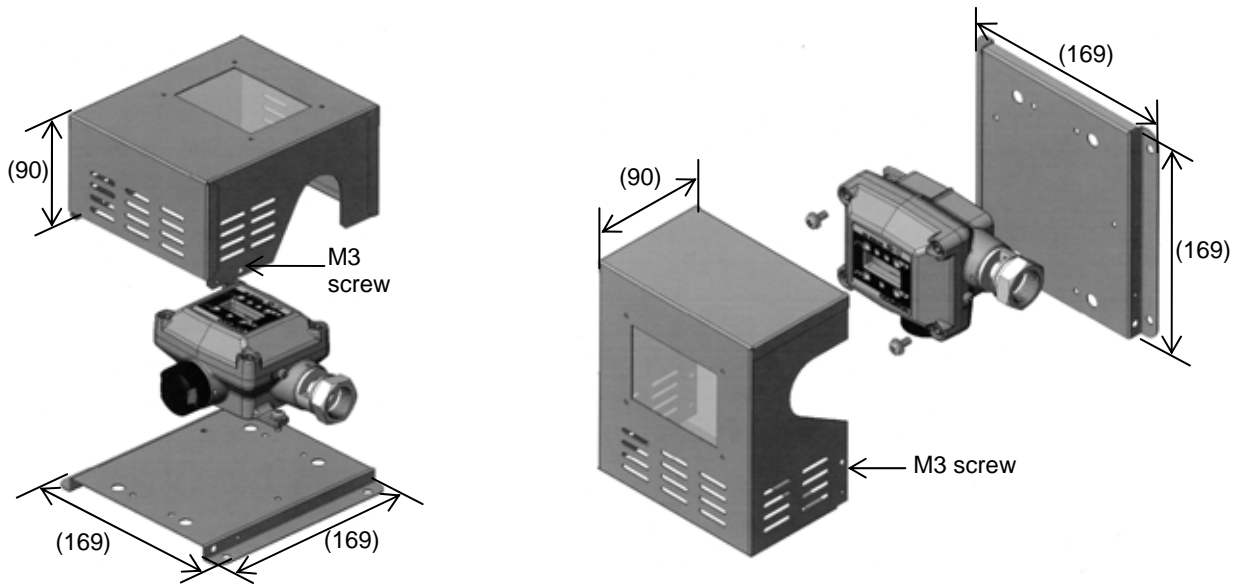

Horizontal Type (KW-41)

Vertical Type (KW-42)



CAUTION

- Secure the casing cover with M3 screws if strong winds are expected.

- 2B Pole Mounting Bracket

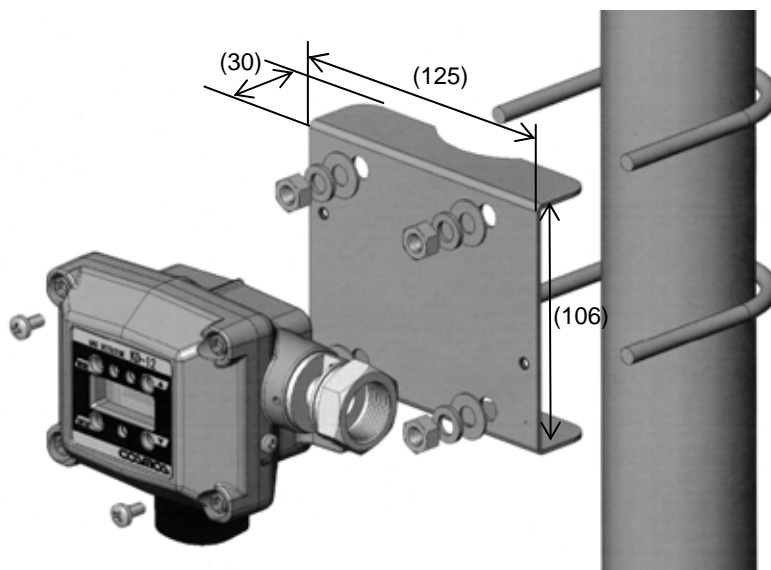

6. Wiring Method

6-1. Wiring Work

- Be sure to provide explosion-proof wiring if the product is to be used in hazardous places.



CAUTION

- Licensed members should implement all necessary work for the product including wiring and installation in accordance with all applicable laws, regulations and standard.

Cable Work

- Use a shielded cable, such as CVV-S with a thickness of 1.25 to 2.00 mm². Lay all cables in protective tubes, such as metal conduits or carbon steel pipes, or other protective structure, such as a concrete duct.
- When using the external contact function of the product, which requires a five-conductor cable, make sure that the maximum diameter of the cable conductor is 1.25 mm². When using only the analog signal function, which requires a three-conductor cable, without the external contact function, make sure that the maximum diameter of the cable conductor is 2.00 mm².
- When using the explosion-proof packing lead-in method, refer to the following table and use a cable with the finished diameter matching the inner diameter of the packing. In order to prevent the spread of explosive gas or fire, securely tighten the cable gland.
- It is recommended not to connect two cables together. If it is unavoidable, however, connect them or branch them within the explosion-proof casing of the main unit.

Cable outer dia.	Packing	Washer	Clamp	Accessory or Optional item
	Inner dia.	Inner dia.		
10 to 10.4	11.5	11	C Clamp	Optional item
10.5	12	11		Accessory
11	12	11		
11.5	12.5	12	B Clamp	Built-in accessory
12	13	12		Accessory
12.5	13.5	14	A Clamp	Optional item
13	14	14		

* A pressure-tight packing with a diameter of 12.5 mm, a washer with a diameter of 12 mm, and a B clamp, all of which correspond to a cable with a diameter of 11.5 mm, are built into the standard model.

* A pressure-tight packing with a diameter of 12 mm and one with a diameter of 13 mm, two washers with a diameter of 11 mm, and a C clamp are provided with the standard model to correspond to cables with a diameter of 11 or 12 mm.

* If the cable diameter is other than 11 or 12 mm, select the corresponding pressure-resistant packing, washer, and clamp from the above table, and order them from New Cosmos.

6-2. Wiring and Connection



WARNING

- Before opening the casing cover of the gas detector, be sure to turn off the product and all devices (e.g., indicator unit and signal converter) connected to the product.
- If the power is turned ON, the power supply may become a source of ignition.
- Be sure to ground the product to prevent electric shocks.



CAUTION

- Wire the connecting terminals correctly.
- Separate connection cables from power lines as far as possible.

Connecting Power Supply and Signal Wires

- Provide dedicated breakers, if needed, to lines that are connected to peripheral devices, such as indicator units and signal converters.
- Use a dedicated cable, such as CVV-S (with a thickness of 1.25 to 2.00 mm²).
- Make sure that the power supplied to the product is within the specified voltage range.
- Make sure that the load resistance of the signal line, including the resistance of the wire, is 300 ohm or less.

MEMO

- If the main unit is grounded on the power supply side, do not connect a shielded cable to the ground terminal (E) in the gas detector, or otherwise two-point grounding will result.

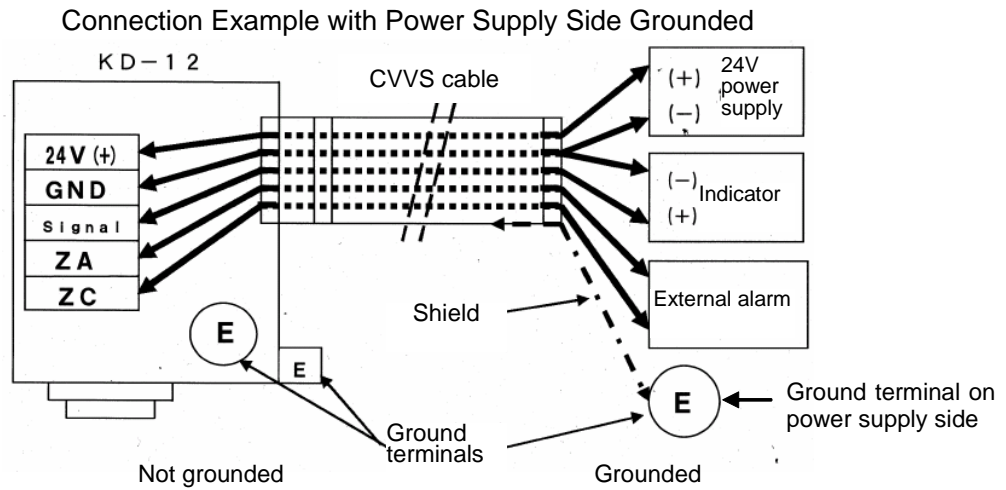

System Configuration Example

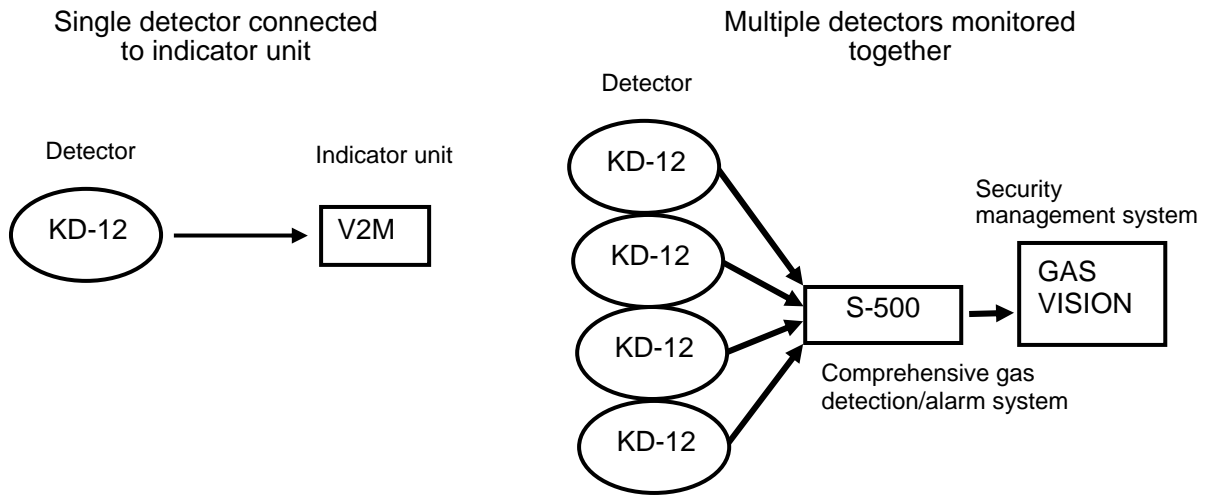

- For details, refer to the Instruction Manual of each device.

Typical Connection Procedure

- (1) Prepare a power supply that can provide 24 V.
(Do not turn on the power supply before wiring the main unit.)
- (2) Loosen the hexagon socket bolts on the four corners of the main unit using the provided hexagon wrench with a nominal diameter of 4 mm, and open the casing cover of the main unit.
- (3) Remove the screws of the cable gland and insert the cable for wiring.



- (4) Press the lever of the terminal block with a flat-blade screwdriver.
- (5) The clamp will open. Insert the lead wire.
- (6) Connect the positive side of the power supply to the 24 V (+) terminal.
- (7) Connect the negative side of the power supply to the GND terminal.



- (8) The lead wire will be automatically secured when the screwdriver is lifted.
- (9) Check that the power supply cords are securely connected to the terminals. This completes the power supply preparations.
- (10) Wire the analog signal and external contact terminals, if required.
- (11) Tighten the hexagon socket bolts on the four corners of the main unit and close the casing cover of the main unit.



CAUTION

- When operating the lever of the terminal block, be careful not to allow the flat-blade screwdriver to slip off the lever. Otherwise, the flat-blade screwdriver may damage the harness or circuit board.
- When operating the lever of the terminal block, do not apply force at an angle.
- When operating the lever of the terminal block, do not apply any force after the lever reaches the stop position.
- When closing the casing cover, make sure that the casing cover does not catch the power supply cord, harness, and O-ring.

7. Precautions before Use



CAUTION

- Before turning ON any of the devices (e.g., indicator unit, signal converter) connected to the product, recheck that all of the connections are correct. Make sure that the gas detector and indicator unit or signal converter, in particular, are connected properly.

● In Case of Gas Leakage



DANGER

- Without panicking, check that there is no fire around the product. Do not touch any electric switches under any conditions. Sparks from turning electric switches ON or OFF may cause ignition.



WARNING

- If there is a gas leak alarm, take the necessary measures specified by your company.
- If a gas leak occurs indoors, open the windows and doors to ventilate the room.
- Check the gas leakage location and promptly take the necessary measures.

8. Display at Start-up (Initial Delay)



CAUTION

- Check that there is no gas around the product before starting the product.
- If the sensor output is not stable, the external contact point may operate after the initial delay. Release the interlock of the external equipment if necessary.
- During the initial delay, the analog signal fixed at 4 mA will be output and the external contact will not operate.

MEMO

- The magnetic stick is not operable during the initial delay.
- The initial delay lasts approximately 30 seconds after the power is turned ON.

- (1) When the power supply is turned ON, all of the indicator lamps (green, red, and yellow lamps) and the display block are lit.



- (2) While the indicator lamps (green, red, and yellow lamps) are lit, the following items will be lit for approximately 1 second each.

Software version number (of the main unit)



Full scale

Example [**2000**] ppm
When the full-scale value is 2000 ppm.



Alarm set value

Example [**500**] ppm
When the alarm set value is 500 ppm.

- (3) Then the POWER indicator (green lamp) will be flashed for approximately 25 seconds.
- (4) When the POWER indicator (green lamp) is lit, the start-up of the main unit is completed and the main unit will be in gas monitor mode.

MEMO

- If the sensor unit has not been turned ON for a long time after the product is shipped from factory, it may take some time for the sensor output to stabilize.
- If needed, turn ON the product for approximately one week, and make the zero adjustment and span adjustment. Refer to 11.3 Calibration Method for the adjustments.

9. Display and Operation in Each Mode

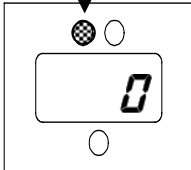
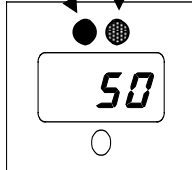
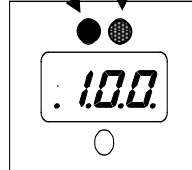
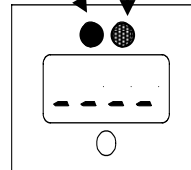
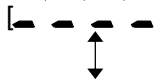
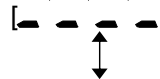
		In excess of alarm set value			
	At start-up (Initial delay)	Gas monitor mode	Test mode	Maintenance mode	
				Gas monitor mode	Test mode
Contents of display	<p>Green lamp flashes</p> 	<p>Green lamp is ON</p> <p>Red lamp flashes</p> 	<p>Green lamp is ON</p> <p>Red lamp flashes</p> 	<p>Red lamp flashes</p> <p>Green lamp is ON</p> 	
	<p>The value according to gas concentration is displayed. The value gradually approaches zero.</p>	<p>Gas concentration is displayed.</p>	<p>[Set concentration]</p> <p>A full-scale test from -10% to 110% is possible.</p>	 <p>[Gas concentration]</p> <p>Displayed alternately</p>	 <p>[Test value]</p> <p>Displayed alternately</p>
Analog signal 4 to 20 mA	Fixed at 4 mA	Gas concentration value is output.	Test value is output	Gas concentration value is output.	Test value is output.
Contact operation	Does not operate (OFF).	Operates (ON).	Operates (ON).	Does not operate (OFF).	Does not operate (OFF).

10. Trouble Alarm

- The product has a self-inspection function, and the trouble alarm will operate if a problem occurs.
- The product will inform the user of the problem details with the display shown in the following table when the trouble alarm operates.
- When the trouble alarm is generated, the analog signal will be approximately 0.9 mA or below.

Screen display	Trouble indicator	Problem details	Probable cause	Remedy
<i>E-24</i>	Yellow lamp flashes	Power supply voltage drop error	The power supply voltage is low.	Check the power supply voltage.
<i>E- 8</i> <i>E- 9</i>	Yellow lamp flashes	Sensor error	The sensor connector is disconnected or the sensor wire has broken.	Check that the sensor connector is securely connected. If a sensor connector failure or broken wire has possibly occurred, contact your local representative.
<i>E- 6</i> <i>E- 7</i>	Lamp is OFF	Zero-point adjustment error	There is gas in the ambient air.	After checking the ambient air, make the zero adjustment again.
<i>E- 4</i> <i>E- 5</i>	Lamp is OFF	Span adjustment error	The gas concentration applied for adjustment is wrong.	After checking the type and concentration of gas, make a span adjustment again. If the type and concentration of gas is suitable, make span rough adjustment.

- If a screen other than the above is displayed, refer to the 12. Troubleshooting section. If the product does not reset to normal operation after taking the measures shown in the table or if the problem is not listed in the table, contact your local representative.
- If the product goes into any unintended mode during adjustment or setting, cease operating the product and contact your local representative..

11. Maintenance Check and Operation Method

11-1. Daily Inspection and Periodical Inspection

- Daily inspections are conducted by the user, while periodical inspections are conducted by your local representative.

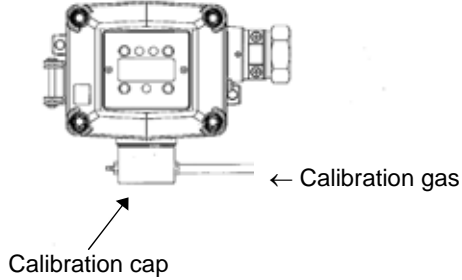
	Frequency	Checking item	Contents of inspection
Daily inspection	At least once per month	Visual inspection	<ul style="list-style-type: none"> • The status of lamp (green POWER indicator) is lit. • The concentration display of the gas concentration indicator. • Clogging of sensor unit mesh. • Corrosion of sensor unit mesh. • Corrosion of the main unit. • Corrosion of mounting screw. If a failure is found, replace the parts.
	Minimum intervals of 2 to 3 months	Alarm operation check with real gas	Apply inspection gas to the gas detector and check the operation of the alarm. <ul style="list-style-type: none"> • Use the calibration cap, apply inspection gas, and check the operation of the alarm. 
		Condition around gas detector	Check that nothing interrupts the diffusion of gas around the gas detector.
Periodical inspection	At least once per year	Consult your local representative.	

- Use optional products to make actual gas inspections.

Periodical Inspections

In order to maintain the reliability of the gas detection/alarm system, it is extremely important to conduct maintenance and inspections.

Moreover, it is necessary to use actual gas (combustible gas or poisonous gas), to carefully conduct inspection and calibration. It is highly recommended that you consider periodical inspections under a maintenance contract with your local representative.

11-2. Preparing Calibration Gas

- Calibration gas is used for actual gas inspection.
- The following example shows how to prepare 0.72 vol% (40%LEL) isobutane as a reference gas.

With a standard gas cylinder

- Fill a gasbag with standard gas as shown in the figure below.
- Completely vacuum air from the gasbag before filling the gas because the air in the bag may cause an error of the gas concentration.

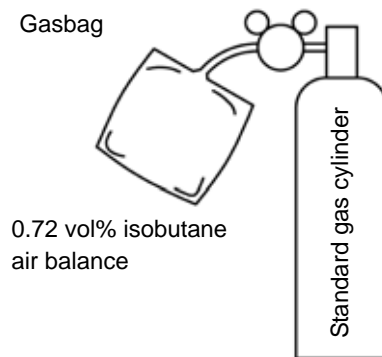

MEMO

- Use a urethane gasbag. Leave for about 30 minutes after drawing the gas and bring humidity in the bag close to the ambient condition before use.

With no calibration gas cylinder

- Use the Gas Calibration Kit (optional item) and a pure gas cylinder of isobutane at 99 vol% or more, and dilute the isobutane with air to produce 0.72 vol% (40%LEL) calibration gas.

Memo The calibration gas can be used to check the alarm function. Check the concentration using Gas Detector XP-3110 or a similar device before using the gas for calibration.



DANGER

Make sure that there are no flammables nearby when handling flammable gas with a concentration over LEL (lower explosive limit).

(1) Drawing raw gas

Connect a gasbag to an isobutane 99vol% cylinder and draw a little more than you actually need.

Bend back the hose and pinch with a pinchcock so the gas does not leak from the bag.

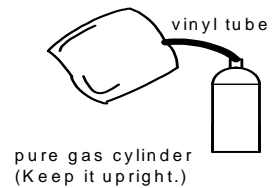

(2) Drawing a fixed amount of raw gas

Connect a 10ml syringe to a gasbag and draw 7.2ml of raw gas. (Draw a little more than you actually need then discharge the excess.)

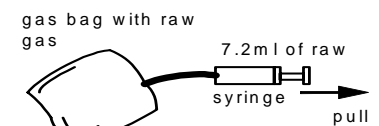

(3) Transferring raw gas into a quantitative pump

Connect a syringe to the inlet of a quantitative pump then pull out the pump's piston. Raw gas in the syringe is sucked into the pump. Remove the syringe and pull the piston all the way out (100ml).

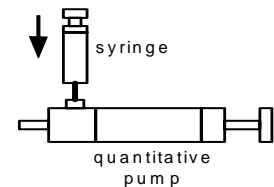

(4) Making diluted gas

Connect an empty gasbag to the outlet of the quantitative pump then push in the pump's piston.

Move the piston back and forth 9 times to add air in order to make diluted gas.

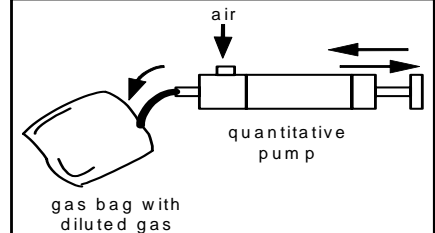

Memo

If you take 7.2ml of raw gas and move the quantitative pump's piston back and forth 10 times (a back-and-forth motion: 100ml),

$$7.2\text{ml}/(100\text{ml}\times 10)=0.0072$$

0.72vol% diluted gas is made.

Isobutane's lower explosive limit (LEL) is 1.8vol%.

$$0.72/1.8\times 100=40.0$$

40%LEL diluted gas is made.

11-3. Calibration Method

● Maintenance Mode



CAUTION

- While in maintenance mode, the external contact does not operate when the concentration of gas reaches or exceeds the alarm set value. The product in maintenance mode maintains the current status while the display shows [— — — —]. This mode is canceled by repeating the same operation (1 to 4), turning the product OFF, or waiting 8 hours.

- (1) While in gas monitor mode, press the MODE switch of the main unit first. Then press the UP switch with the magnetic stick within approximately 2 seconds.
- (2) The main unit displays **CAL.** first, followed by **. . .0.**
(The product is ready to work but nothing has been operated.)
- (3) Press the UP or DOWN switch of the main unit with the magnetic stick and adjust the value to **. . .0.**
- (4) Press the ENTER switch of the main unit.



— — — —
↑
[Gas concentration]

- (5) When the above items displayed alternately, the product has been set to maintenance mode.
- (6) Upon completion of this mode, the product will automatically return to gas monitor mode.
- (7) While **— — — —** is displayed, the maintenance mode is being executed.
- (8) This mode will be canceled by repeating the same operation (1 to 4 above), turning the product OFF, or waiting for 8 hours.

Carefully handle and make settings with the magnetic stick because the magnet is very powerful. For details, refer to 3. Contents of Package.

● Zero Adjustment

- The external contact may operate. Therefore, set the product to maintenance mode if needed.

MEMO

Conduct the zero adjustment in a place where there is no ambient gas.

- (1) While in gas monitor mode, press the MODE switch of the main unit first. Then press the UP switch with the magnetic stick within approximately 2 seconds.
- (2) The main unit displays *CAL.* first, followed by *0.*
(The product is ready to work but nothing has been operated.)



- (3) Press the UP or DOWN switch of the main unit with the magnetic stick and adjust the value to *0.000.*
- (4) Press the ENTER switch of the main unit.
- (5)

2.E.r.o.

0

Good

- (6) When the above items are displayed, the zero adjustment is completed.
- (7) Upon completion of the zero adjustment, the product will automatically return to gas monitor mode.

- If an error is displayed, refer to 10. Trouble Alarm.
- Carefully handle and make settings with the magnetic stick because the magnet is very powerful. For details, refer to 3. Contents of Package.

● Span Fine-tuning

MEMO

Be sure to conduct the zero adjustment before performing span fine-tuning.



CAUTION

- The external contact may operate during span fine-tuning. Set the product to maintenance mode or release the interlocks of the external devices if needed before performing span fine-tuning.
- Only your local representative's maintenance service members or personnel who have completed a maintenance seminar can perform fine-tuning.

- (1) Apply calibration gas corresponding to the equipment.

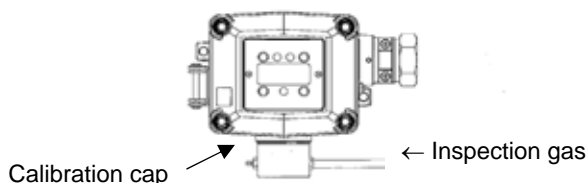

- (2) Sufficiently stabilize the gas.
- (3) While in gas monitor mode, press the MODE switch of the main unit first. Then press the UP switch with the magnetic stick within approximately 2 seconds.
- (4) The main unit displays **CAL.** first, followed by **.0**.
(The product has completed starting but nothing has been operated.)
Example: After zero adjustment, **. . .!** will be displayed.
- (5) Press the UP or DOWN switch of the main unit with the magnetic stick and adjust the value to **. . .2**.
- (6) Press the ENTER switch of the main unit.
- (7) The main unit displays **S.F.** first, followed by the present gas concentration.
- (8) Press the UP or DOWN switch of the main unit with the magnetic stick, and adjust the display of the main unit to the actual span gas concentration.
- (9) Press the ENTER switch.
- (10) The span fine-tuning is completed when **Good** is displayed.
- (11) Upon completion of the span fine-tuning, the product will automatically return to gas monitor mode.
- (12) Remove the gasbag.

- Perform span rough adjustment if **E- 4** or **E- 5** is displayed.
- If an error is displayed, refer to 10. Trouble Alarm.
- Carefully handle and make settings with the magnetic stick because the magnet is very powerful. For details, refer to 3. Contents of Package.

● Span Rough Adjustment

- Perform span rough adjustment if **E- 4** or **E- 5** is displayed.



CAUTION

- The external contact may operate during span rough adjustment. Before performing span rough adjustment, set the product to maintenance mode or release the interlocks of the external devices if needed.
- Only your local representative's maintenance service members or personnel who have completed a maintenance seminar can perform span rough adjustment.

- (1) Apply calibration gas corresponding to the equipment.
- (2) Sufficiently stabilize the gas.
- (3) While in gas monitor mode, press the MODE switch of the main unit first. Then press the UP switch with the magnetic stick within approximately 2 seconds.
- (4) The main unit displays **CAL.** first, and displays **.0.**
(The product is ready to work but nothing has been operated.)
Example: After zero adjustment, **. . .!** will be displayed.
- (5) Press the UP or DOWN switch of the main unit with the magnetic stick and adjust the value to **. . .7.**
- (6) Press the ENTER switch of the main unit.
- (7) The main unit displays **Sr.** first, and displays the present gas concentration.
- (8) Press the UP or DOWN switch of the main unit with the magnetic stick, and adjust the display of the main unit close to the actual span gas concentration.
- (9) Press the ENTER switch.
- (10) The span rough adjustment is completed when **Good** is displayed.
- (11) On completion of the span rough adjustment, the product will automatically return to gas monitor mode.
- (12) Remove the gasbag.

MEMO

Precise adjustment is not performed only by span rough adjustment. Perform span fine-tuning after span rough adjustment.

- If an error is displayed, refer to 10. Trouble Alarm.
- Carefully handle and make settings with the magnetic stick because the magnet is very powerful. For details, refer to 3. Contents of Package.

● Full-scale and Alarm Set Value Display

- The full-scale and alarm set values are only displayed. They cannot be changed.
- (1) While in gas monitor mode, press the MODE switch of the main unit first. Then press the UP switch with the magnetic stick within approximately 2 seconds.
 - (2) The main unit displays **CAL.** first, and displays **0.0**.
(The product is ready to work but nothing has been operated.)
Example: After zero adjustment, **0.1** will be displayed.
 - (3) Press the UP or DOWN switch of the main unit with the magnetic stick and adjust the value to **4**.
 - (4) Press the ENTER switch of the main unit.



F.S.d.P.

F.S.

Full scale

AL.

Alarm set value

- (5) When the above items are displayed in sequence and repeatedly, the user can check the full-scale and alarm set values.
 - (6) After the full-scale and alarm set values are displayed, the product will automatically return to gas monitor mode.
- Carefully handle and make settings with the magnetic stick because the magnet is very powerful. For details, refer to 3. Contents of Package.

● Test Mode

- Test values are adjusted and used for tests in this mode.



CAUTION

- The external contact may operate while the product is in test mode.
Before setting the product to test mode, set the product to maintenance mode or release the interlocks of the external devices if needed.

- (1) While in gas monitor mode, press the MODE switch of the main unit first. Then press the UP switch with the magnetic stick within approximately 2 seconds.
- (2) The main unit displays **CAL.** first, and displays **. . . 0 .**
(The product is ready to work but nothing has been operated.)
Example: After zero adjustment, **. . . 1 .** will be displayed.
- (3) Press the UP or DOWN switch of the main unit with the magnetic stick and adjust the value to **. . 10 .**



- (4) Press the ENTER switch of the main unit.

L.E.S.L.

Test value

- (5) When the above items are displayed, the test operation of the product in a concentration range from -10% to 110% of the full scale.
The test operation of the product is possible in a concentration range from -200 to 2200 ppm if the full scale of the product is 2000 ppm.
The test operation of the product is possible in a concentration range from -10%LEL to 110%LEL if the full scale of the product is 100%LEL.
 - (6) Press the UP or DOWN switch of the main unit and set the desired calibration concentration. Then the test will start.
If the setting is outside the operating range, **LLLL** or **HHHH** will be displayed.
 - (7) To quit the test mode, press the ENTER or MODE switch.
 - (8) When the test is finished with the ENTER switch pressed, the tested value will be saved.
When the test is finished with the MODE switch, the previously saved value will remain.
- Carefully handle and make settings with the magnetic stick because the magnet is very powerful. For details, refer to 3. Contents of Package.

11-4. Replacement of Sensor Unit



WARNING

- Be sure to turn OFF the indicator unit or signal converter before replacing a sensor unit. Otherwise, they may become a source of ignition.



CAUTION

- The setup data of the Detector may have to be re-written depending on the type of the sensor. Only your local representative's maintenance service members or personnel who have completed a maintenance seminar can replace the sensor unit.
- Be sure to handle the sensor unit with care. Do not drop or throw the sensor unit. Otherwise, the sensor wire may be disconnected or a sensor failure may result.
- The external contact may operate when replacing the sensor unit if the sensor output is not stable. Release the interlocks of the external devices if needed.
- When removing or mounting the sensor unit, do not twist the harness of the sensor connector.
- When closing the casing cover, make sure that the power supply cord, harness, or O-ring is not caught by the casing cover.

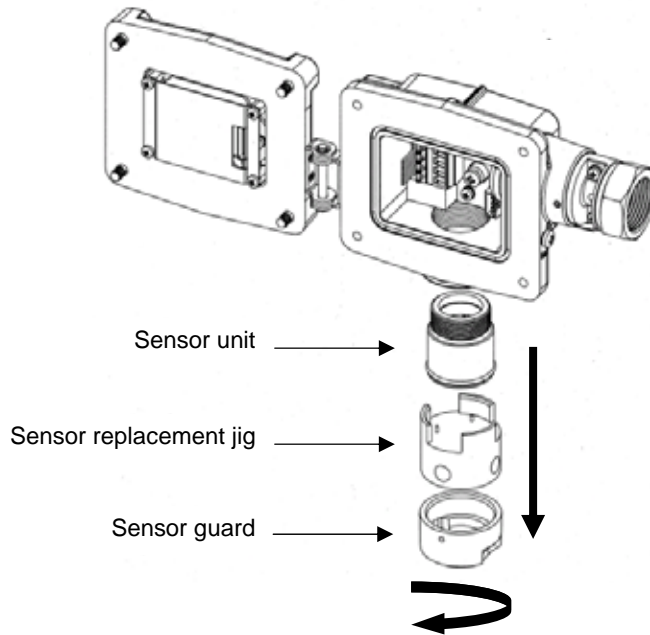

- (1) Turn OFF the power supply connected to the product.
- (2) Loosen the bolt with a hexagon socket on each of the four corners of the main unit with the provided hexagon wrench with a nominal diameter of 4 mm, and open the casing cover of the main unit.
- (3) Disconnect the sensor connector.
- (4) Dismount the sensor guard.
- (5) Use the sensor replacement jig, and turn and pull out the sensor unit.
- (6) Insert a new sensor unit and tighten the sensor unit by using the sensor replacement jig.
- (7) Connect the sensor connector.
- (8) Check that the sensor connector is connected securely.
- (9) Mount the sensor guard.
- (10) Tighten the bolt with a hexagon socket on each of the four corners of the main unit with the provided hexagon wrench with a nominal diameter of 4 mm, and close the casing cover of the main unit.
- (11) Turn ON the power supply connected to the product.
- (12) When the sensor unit has been replaced, it is necessary to make zero adjustment and span adjustment after keeping the product turned ON for approximately one week to stabilize the sensor output.
- (13) Be sure to make zero adjustment first, followed by span adjustment.
- (14) If an error is displayed, refer to 10. Trouble Alarm.

MEMO

- The sensor replacement jig is an optional product.
- Return the used sensor unit to your local representative.

12. Troubleshooting

- Before requesting repairs, refer to the following table. Consult your New Cosmos representative if the product does not return to normal after taking the corresponding remedies shown below or if the defective condition is not found in the table.
- If the product goes into an unintended mode at the adjustment or setting stage, stop operating the product immediately and consult the system administrator.

Defective condition	Probable cause	Remedy	Reference page
The green power lamp is not lit.	Incorrect wiring connection.	Check and redo the wiring.	P. 12 Wiring and Connection
The yellow lamp to indicate an error is flashed and the error code is displayed.	E-24 Low-voltage state	Check the power supply voltage.	P. 12 Wiring and Connection
	E-8 E-9 The sensor unit is defective, the connector is disconnected, or the sensor wires are broken.	Check that the sensor connector is connected securely. If there is a possibility that the sensor is defective or sensor wires are broken, contact your local representative.	
The detected gas concentration and ---- are flashing alternately.	The product is in maintenance mode.	Return the product to gas monitor mode.	P. 22 Maintenance Mode
There is no alarm contact output.	The product is in maintenance mode.	Return the product to gas monitor mode.	P. 22 Maintenance mode
	Incorrect wiring connection.	Check and reconnect the wiring.	P. 12 Wiring and Connection
	The alarm point setting is wrong.	Check the alarm setting.	P. 26 Full-scale and Alarm Set Display
The analog signal does not change	The product is in test mode.	Return the product to gas monitor mode	P. 27 Test mode
A value and HHHH are flashing alternately.	The sensor output is high.	The concentration of gas is in excess of the full scale. Check the ambient environment.	
A value and LLLL are flashing alternately.	The sensor output is low.	Conduct zero adjustment after checking that the air around the product is not contaminated with gas.	P. 23 Zero adjustment
No adjustment or setting is possible.	The product is operated during the initial delay time.	Operate the product after the 30-second initial delay time.	P. 16 Display at Start-up (Initial Delay)

13. Specifications

Corresponding sensor type	Hot wire semiconductor type (KD-12A), Catalytic combustion type (KD-12B), Thermal Conductivity type (KD-12C)
Sampling method	Diffusion type
Detection gas	Depends on the specifications.
Detection range	Depends on the specifications.
Gas concentration display	Four-digit digital LED display
Alarm set value	Depends on the specifications.
Alarm accuracy	<ul style="list-style-type: none"> • Combustible gas: $\pm 25\%$ of alarm set value under identical conditions. • Toxic gas: $\pm 30\%$ of alarm set value under identical conditions.
Alarm delay	<ul style="list-style-type: none"> • Combustible gas: Within 30 seconds with gas concentration that is 1.6 times as high as the level of alarm set concentration. • Toxic gas: Within 60 seconds with gas concentration that is 1.6 times as high as the level of alarm set concentration.
Warning display	<ul style="list-style-type: none"> • Gas alarm (one stage only) Red LED lamp flashes • Trouble alarm (sensor disconnection, sensor zero drop, power supply voltage error, or internal EEPROM communication error) Yellow LED lamp flashes
External output	<p>Gas concentration analog signal</p> <ul style="list-style-type: none"> • 4 to 20 mA DC (common to the negative side of power supply) • 0.9 mA DC or less at the time of Trouble alarm. • Make sure that the load resistance of the analog signal is less than 300 ohm including the wiring resistance. <p>Gas alarm contact (one stage only)</p> <ul style="list-style-type: none"> • 1a no-voltage contact output/Non-latching • Rated load: 0.5 A at 250 VAC or 0.5 A at 30 VDC (resistance load)
Explosion-proof performance	Exd II CT5
Degree of protection	IP65 (interior)
Applicable cable	<p>Cable outer diameter (10 to 13 mm)</p> <ul style="list-style-type: none"> • In the case of a 5-conductor cable (for power supply, gas concentration analog signal, and gas alarm contact): CVV-S 1.25 mm². • In the case of a 3-conductor cable (for power supply and gas concentration analog signal) CVV-S 2 mm²
Operating temperature and humidity ranges	<ul style="list-style-type: none"> • Temperature: -10°C to 50°C • Humidity 10% to 90% (0 to 50°C). (No radical temperature or humidity changes and no condensation)
Power supply	24 VDC (18 to 30 VDC)
Power consumption	3 W max.
Size	158 (W) x 116 (H) x 68 (D) mm (excluding protruding parts)
Weight	Approx. 1.2 kg
Mounting method	Wall mounting

The above specifications are subject to change without notice.

If your specifications are nonstandard, refer to the delivery specifications.

14. Warranty

New Cosmos Electric Company Limited (New Cosmos) offers the following as the sole and exclusive limited warranty available to the customer.

This warranty is in lieu of, and customer waives, all other warranties of any kind or nature, expressed or implied, including without limitation, any warranty for merchantability or fitness for a particular purpose. The remedies set forth herein are exclusive.

New Cosmos warrants to the original purchaser and no other person or entity (the customer) that the gas detection product supplied by New Cosmos shall be free from defects in materials and workmanship for a period of one (1) year from the date of purchase. This warranty does not include consumables, such as fuses, filters, etc. Certain other accessories not specifically listed here may have different warranty periods.

After examination of an allegedly defective product returned to New Cosmos, with freight prepaid, should the product fail to conform to this warranty, the customer's only remedy and New Cosmos's only obligation shall be, at New Cosmos's sole option, replacement or repair of such non-conforming product or refund of the original purchase price of the non-conforming product. In no event will New Cosmos be liable for any other special, incidental or consequential damages or losses of any kind whatsoever, including but not limited to, loss of anticipated profits and any other loss caused by reason of non-operation of the product.

This warranty is valid only if the product is maintained and used in accordance with New Cosmos's instructions and/or recommendations. New Cosmos shall be released from all obligations under this warranty in the event repairs or modifications are made by persons other than its own or authorized service personnel or if the warranty claim results from physical abuse or misuse of the product.

15. Life Expectancy

- The period of designed life expectancy of the product under standard environmental conditions is approximately five years after the date of purchase.
The period of designed life expectancy after the expiration of the warranty period is a rough standard on the condition that the product is used with specified gas calibration performed. New Cosmos, however, does not guarantee the specified period of designed life expectancy. The product may become unusable before the next calibration is performed.
- The life of the hot wire semiconductor-type sensor incorporated in the KD-12A is approximately five years after the date of purchase.
The sensor may not detect gas correctly with the lapse of approximately five years. Replace the sensor at intervals of approximately five years. The life of the sensor is specified on the condition that the sensor is serviced properly and that the sensor is not exposed to high-density gas or toxic gas. New Cosmos, however, does not guarantee the specified life of the sensor.
- The life of the catalytic combustion-type sensor incorporated in the KD-12B is approximately three years after the date of purchase.
The sensor may not detect gas correctly with the lapse of approximately three years. Replace the sensor at intervals of approximately three years. The life of the sensor is specified on the condition that the sensor is serviced properly and that the sensor is not exposed to high-density gas or toxic gas. New Cosmos, however, does not guarantee the specified life of the sensor.
- The life of the thermal conductive-type sensor incorporated in the KD-12C is approximately five years after the date of purchase.
The sensor may not detect gas correctly with the lapse of approximately five years. Replace the sensor at intervals of approximately five years. The life of the sensor is specified on the condition that the sensor is serviced properly and that the sensor is not exposed to high-density gas or toxic gas. New Cosmos, however, does not guarantee the specified life of the sensor.

16. Detection Principle

16-1 . Catalytic Combustion

- Catalytic combustion occurs on the catalyst even at a gas concentration below the lower limit of combustion due to the operation of the catalyst applied to the platinum coil. The electrical resistance of the platinum coil increases because of the rise in the temperature at this point. This difference is extracted as deviation voltage in the bridge circuit.

Detection of combustible gases is possible up to the lower explosion limit (LEL).

16-2 . Hot Wire Semiconductor

- When a metal-oxide semiconductor heated by a platinum coil adsorbs an electron-donating gas, such as a combustible gas, its electron concentration increases and the thermal conductivity of the semiconductor improves. As a result, the temperature of the semiconductor falls and the resistance of the platinum wire reduces. This difference is extracted as deviation voltage in the bridge circuit.

The feature of this sensor is its extreme sensitivity at low temperatures, which makes it suitable for sensitive detection.

16-3 . Thermal Conductivity

- As compared to when only air is present around the sensor, the heat dissipation state of the detection piece (heated to around 150 °C) to which an inert substance is applied and sintered on a platinum wire varies with the increase or decrease in the thermal conductivity of the gas, and the temperature of the detection piece changes. This difference is almost proportional to the gas concentration, and therefore, the difference in the resistance of the platinum wire can be extracted as deviation voltage of the bridge circuit.

Although only gases whose thermal conductivity is different from air can be measured, it is possible to detect high-concentration gases between 0% and 100% by volume.

17. Glossary

Indicator / Alarm unit:	A unit that receives signals from the gas detector and indicates gas concentration and alarms.
Detector:	A unit that detects gas concentration and converts it to electric signals.
Backup power source device:	A device that supplies power to the gas detector, indicator / alarm unit in order to maintain its performance during a power failure.
Flow meter:	A meter to measure air flow in gas sampling pipe.
Gas collector:	A gas collecting probe that enhances gas collection efficiency and blocks water and dust.
Diffusion type:	A method to detect gas by utilizing convection and diffusion of gas.
Explosion proof construction:	A totally enclosed structure. When an explosive gas explodes in a container, the container can resist the pressure and prevent the ignition of explosive gases outside of it.
Preset alarm value:	A preset value for the alarm to go off when gas concentration reaches a certain value.
Gas to be detected:	Gas that is detected and indicated which sets off an alarm.
Detection range:	Range of gas's concentration that can be indicated and set off an alarm.
Alarm accuracy:	Difference between the preset alarm value and gas concentration when an alarm actually occurs or as the percentage of the difference compared to the preset alarm value.
Response time:	Time it takes from when the gas detector is exposed to a gas with a concentration higher (lower) than the preset alarm value until an alarm goes off.
Temperature range:	Range of temperature where the equipment can perform its functions.
Maintenance and inspections:	Work to guarantee that the equipment perform its required functions.
Calibration gas:	Gas used to calibrate scales of the equipment.
Peak hold:	A function to constantly update and hold the peak value of input signals.
Hazardous area:	An area in a plant or facility with a hazardous atmosphere

where explosive gases may mix with air and explode or start a fire. An area where gas may be present.

Non hazardous area: An area where electric equipment that has no potential to create a hazardous atmosphere.

Hazardous atmosphere: Atmosphere within the explosive limit where explosive gas and air are mixed.

LEL: Lower Explosive Limit. The lowest concentration of flammable gas that will explode when mixed with air and ignited.

(Quoted from gas detection terms and detector tube gas meter terms used by the Industrial Gas Detector Alarm Association.)

Manual Revision History

Edition No.	Date	Revisions
GAE-029	September 2007	0
GAE-029-01	May 2010	1

Additional copies of this Instruction Manual are available.
Contact the following address for ordering information.

Distributor:

Manufacturer:

New Cosmos Electric Co., Ltd.
2-5-4 Mitsuya-naka Yodogawa-ku
Osaka 532-0036, Japan
Phone 81-6-6309-1505
Fax 81-6-6308-0371
Email e-info@new-cosmos.co.jp
<http://www.new-cosmos.co.jp>

