

1-Point Type Combustible Gas Detection / Alarm System

Model NV-100H

Instruction Manual

Keep this instruction manual where it is readily accessible.

Thoroughly read this instruction manual before using the equipment so it can be used safely and correctly.

 **New-Cosmos Electric Co., Ltd.**

Instruction manual No.
GAE-017-01
December 2004

Table of Contents

1. Introduction	1
2. Safe Operation	1
3. Unpacking	2
4. System Structure	3
5. Dimensions and Part Names	4
5-1 Indicator and Alarm Unit	4
5-2 Gas Detector	6
6. Installation and Wiring	8
6-1 How to Install the Indicator and Alarm Unit	8
6-2 How to Install the Gas Detector	10
6-3 Wiring Method	13
7. Operating Instructions	15
7-1 Notes to Users	15
7-2 Procedures	15
7-3 Operation of the equipment	17
7-4 When an Alarm Occurs	18
7-5 How to replace Batteries (when the equipment has a backup power source)	18
7-6 Maintenance Function	19
8. Maintenance and Inspections	29
8-1 Regular Inspections (Inspections that the users are responsible for) (See Table 1.)	29
8-2 Maintenance inspections (Contact our dealer / agency for the inspection.)	30
8-3 Preparation of Calibration Gas (used for your actual gas performance test)	31
8-4 Replacing the Gas Sensor	33
8-5 Replacing the Filter (suction type gas detector)	35
8-6 Cleaning the Gap Plate (suction type gas detector PE-2DC)	36
9. Troubleshooting	37
10. Specifications	38
10-1 Indicator and Alarm Unit	38
10-2 Gas Detector	39
11. Consumable Parts and Spare Parts	39
12. Warranty	39
13. Service Life	39
14. Glossary	40

1. Introduction

Thank you for purchasing a NV-100H single-point combustible gas detection /alarm system.

This system is used to prevent leakage of combustible gas. This equipment continuously monitors for leakage of combustible gas, and indicates when a preset level has been exceeded by a lamp and sound.

Thoroughly read this instruction manual before using the equipment so it can be used correctly. Read the instruction manual of the gas detector as well.

Symbols

The following symbols are used for safety purposes:

 **DANGER** : Indicates an imminently hazardous situation which, if not avoided, will result in death or serious injury

 **WARNING** : Indicates a potentially hazardous situation which, if not avoided, will result in death or serious injury

 **CAUTION** : Indicates a potentially hazardous situation which, if not avoided, may result in minor injury or moderate injury. It may also be used to alert against unsafe practices.

 **MEMO** : Operational advice and or instruction.

2. Safe Operation

Carefully read the following so you can use the equipment correctly.

Read and understand all applicable laws and regulations and ensure that you are in complete compliance with the said laws and regulation before installing or operating the equipment.

Installing, wiring, and other works concerning the equipment should be carried out by qualified persons, following all applicable federal, state, and local health and safety laws and regulations including OSHA.

DANGER

Operation checks using actual gas are very dangerous because combustible gas may explode and toxic gas is harmful. An inspection must be carried out beforehand by persons with sufficient expertise or our service staff.

WARNING

- Ground the equipment in order to prevent electric shocks.
- In case of an alarm, carry out your predetermined measures for gas leakage.
- This equipment is not explosion-proof. Install it in a non-hazardous location.

CAUTION

- Do not disassemble, alter the equipment, or change its structure and electric circuit. It may affect the performance of the equipment.
- If you control the interlock of external equipment etc. with equipment's output signal, we are not responsible for any injuries or damages caused by it.
- The equipment is not waterproof. Install it in a place where it will not get wet.
- Follow all related laws and regulations when using the equipment.
- Do not use any equipment that generates electrical noises such as cellular phones or radio-communications within 30 cm of the alarm panel.

3. Unpacking

The following standard components are packed together with the Gas Detector/alarm. Carefully check the contents against the list when unpacking. If any components are missing or damaged, contact our dealer / agency.

NV-100H main body		1
Gas detector head		1
Fuse 1A	Without a backup power source	1
	With a backup power source	2
L shaped-wrench	For Diffusion type gas detector head 2,3,4mm	1 ea.
	For Suction type gas detector head 2,4,5,8mm	1 ea.
Parts to embed the panel (embedded panel only)		1
Air filter FC-32 with flow checker (for Suction type gas detector head only)		1
Sample gas collector PE-N3(for Suction type gas detector head only)		1
NV-100H instruction manual (this book)		1
Test results of the equipment		1
Warranty		1

Options (separately sold)

Rainproof cover	KW-15 for Diffusion type gas detector head KD-5	1
	PW-51 for Suction type gas detector head PE-2DC	1
Rainproof cap	KW-22 for KD-5	1
Auto drain	AD-40	1

4. System Structure

This equipment consists of a part that detects gas (gas detector head) and a part that indicates gas concentration and sets off an alarm (indicator and alarm unit). The parts are connected by cables.

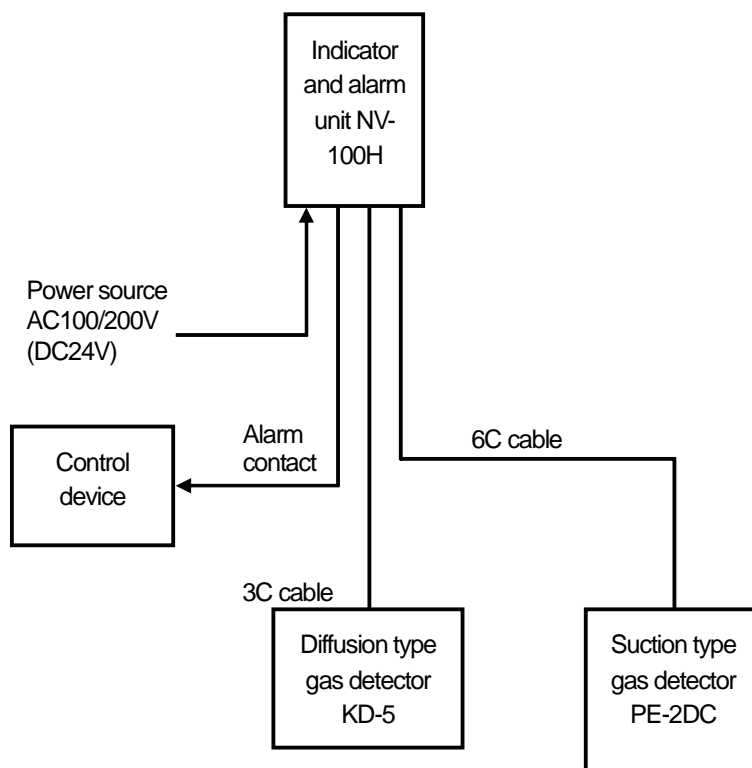

Fig. 1 System Structure

⚠ CAUTION

The indicator and alarm unit is not an explosion-proof construction. Install it in a non-hazardous area.

MEMO

- One gas detector (either diffusion or suction type gas detector) can be connected. Use a rainproof cover (option) if you install the equipment outdoor.
- The number of cores of cables differs according to the gas detector head connected.

5. Dimensions and Part Names

5-1 Indicator and Alarm Unit

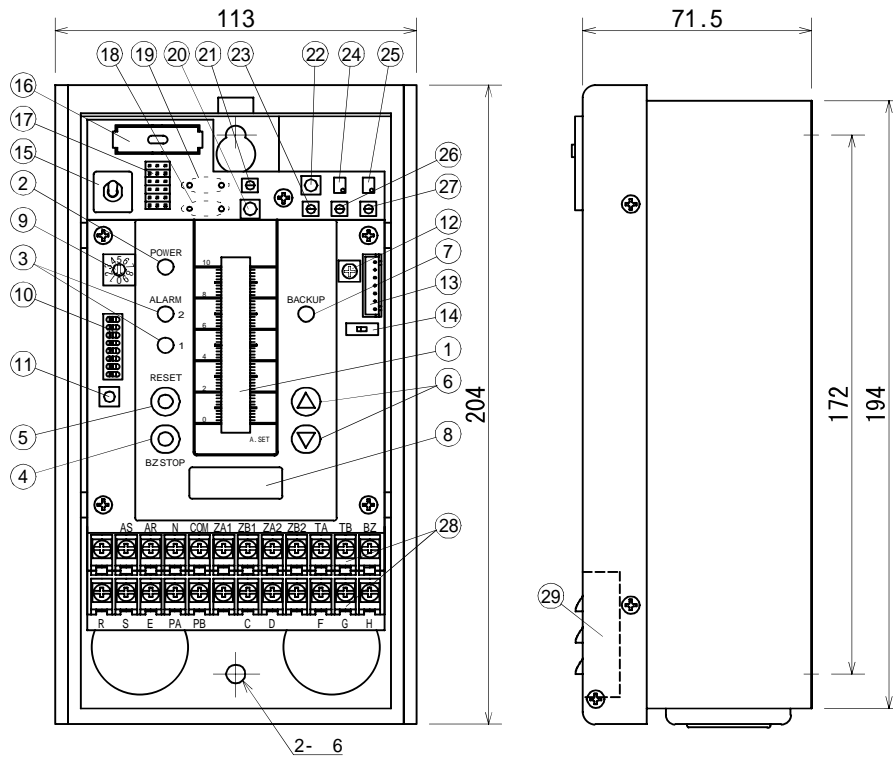

Fig. 2 Dimensions of the Indicator and Alarm Unit (without a backup power source)

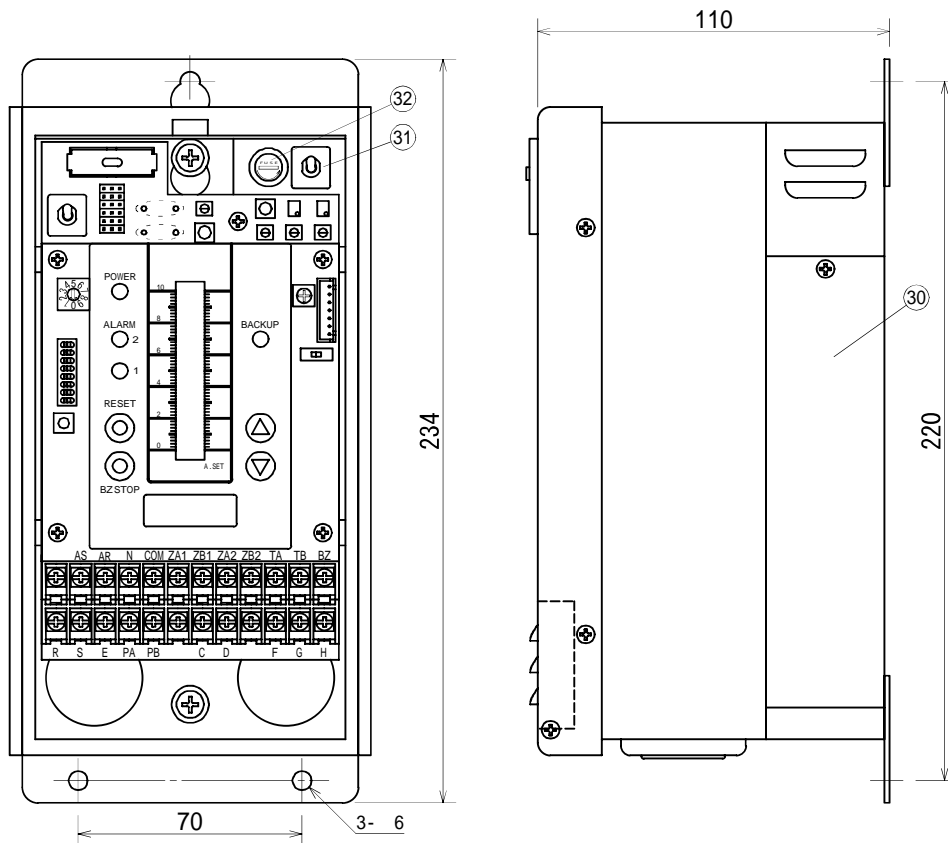
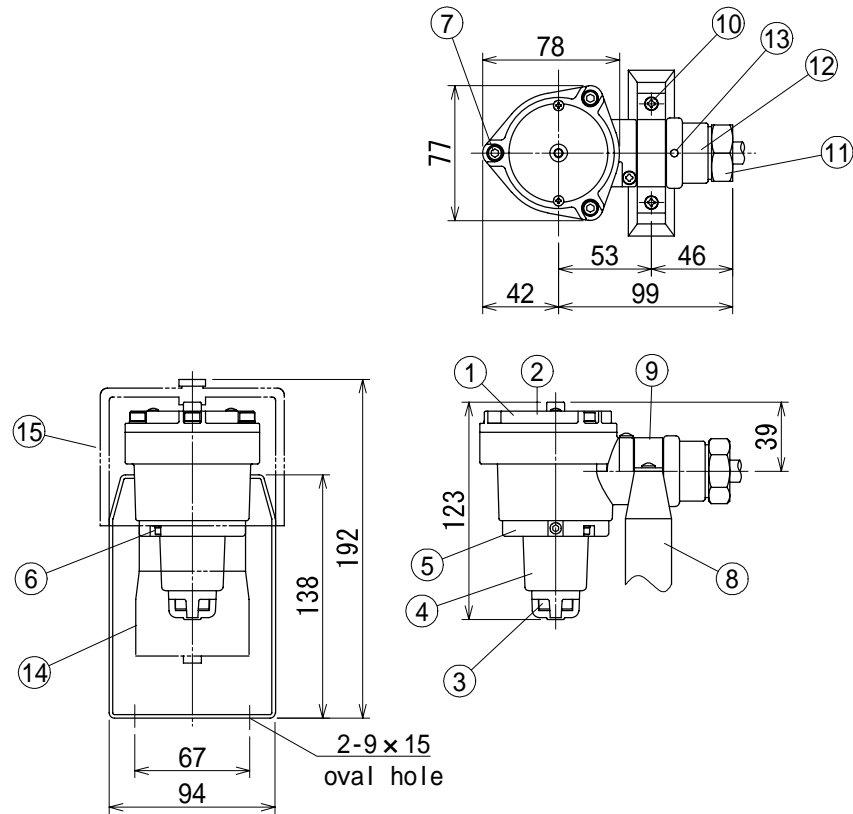

Fig. 3 Dimensions of the Indicator and Alarm Unit (with a backup power source)

No.	Name	Function
1	Gas concentration indicator	This LCD bar graph meter with backlight indicates gas concentration and the preset alarm value. The peak value continues to blink even after the reading value goes down after an alarm.
2	Power lamp (POWER)	It is green during normal operation and orange when the sensor failure. It blinks green when the equipment is turned on and also after a failure has been taken care of to show that the equipment is warming up.
3	Alarm lamp (ALARM)	A red lamp blinks to indicate a gas leakage and lights up when the buzzer stops.
4	Buzzer stop key (BZ STOP)	When this key is pressed, the alarm sound stops and the blinking Alarm lamp lights up.
5	Reset key (RESET)	When this key is pressed after the buzzer stops and reading lowers, the Alarm lamp and peak hold go off. They do not go off when the key is pressed before the buzzer stops.
6	Alarm setting key ()	Use these keys to change the preset alarm value. Press to increase the set value and press to decrease it.
7	Backup lamp (BACKUP)	It is off in normal state and it blinks red during a power failure. (Equipment with an optional backup power sources only.)
8	Message window	Displays messages during operation of functions.
9	Mode switch	Use to set mode such as maintenance mode 1, 2, etc.
10	Function switch	Use to set functions.
11	Enter key	Use to set functions.
12	SOUND volume control	To control alarm buzzer volume. Adjust it when you want to lower the sound.
13	Program connector	Use to write in the program. Usually, it is not used.
14	Program switch	Use to write in the program. Usually, select the left side.
15	Power switch	A switch to open/close the equipment's power source.
16	AC power source fuse	5.2 × 20L 1A glass fuse.
17	Jumper pin	It is used for various settings. No setting by customer is necessary.
18	Sensor signal check terminal (SIGNAL)	A terminal to check gas sensor signals
19	Sensor current check terminal (CURR CHECK)	A terminal to check gas sensor current. It can be checked by Tester's voltage check range due to its built in 1 resistance.
20	Battery test key (B. TEST)	To test the battery's life. This key cannot be used if the equipment does not have a backup power source.
21	Sensor current adjustment control (CURR)	A volume to adjust the gas sensor current.
22	Test button (TEST)	Use this button for performance tests.
23	Test volume (TEST)	A control to adjust what the indicator indicates when the Test button is pressed. It is adjusted so the full scale is indicated.
24	Zero adjustment volume (ZERO)	A control to adjust the gas sensor's zero point. Adjust this in maintenance mode 2.
25	Span adjustment volume (SPAN)	A control to calibrate the indicated value of gas concentration. Adjust this in maintenance mode 2.
26	Analog output adjustment volume (L)	A control to adjust analog output 4 mA (1V)
27	Analog output adjustment volume (H)	A control to adjust analog output 20 mA (5V)
28	Terminal block	A terminal block to connect external wirings
29	Speaker	To sound an alarm
30	Backup power source unit	Supplies power from built-in battery in the event of a power failure.
31	Battery switch	A switch to open/close the battery of the optional backup power source.
32	Battery fuse	5.2 × 20L 1A glass fuse

5-2 Gas Detector

(1) Diffusion type gas detector head KD-5



15	Rainproof cover	1	KW - 15
14	Rainproof cap	1	KW - 22
13	Screw	1	
12	Gland cover	1	
11	Gland	1	
10	Pan-head screw	2	
9	Saddle	1	
8	Stand	1	
7	M5 hexagon socket head bolt	3	
6	M4 hexagon socket head bolt	1	
5	Guard mount	1	
4	Sensor guard	1	
3	Sensor unit	1	
2	Terminal box cover	1	
1	Terminal box	1	
#		Q'ty	Remark

Fig.4 Diffusion type gas detector head (KD-5)

MEMO

Refer to the instruction manual for KD-2A, KD-3A when use gas detector head KD-2A, KD-3A

(2) Suction type gas detector head PE-2DC

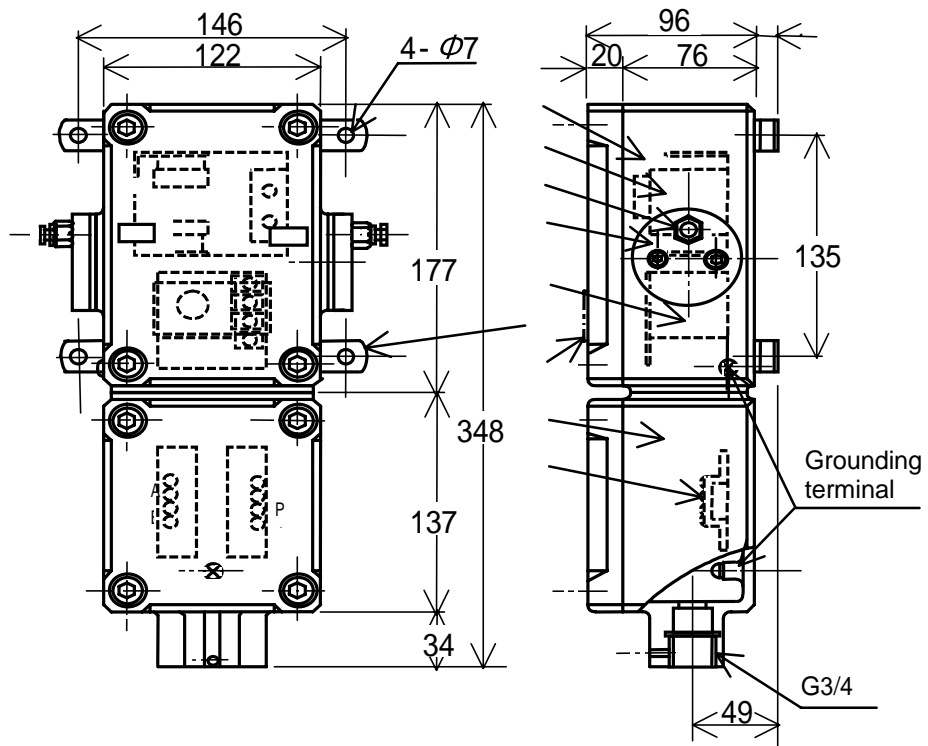

10	Name plate	1	
9		1	
8	Terminal block	1	
7	Suction pump	2	
6	Sensor element	1	
5	Mount	1	
4	Half joint	2	
3	Gap plate	2	
2	Terminal box	2	
1	Detector main body	1	
#		Q'ty	Remark

Fig.5 Suction type gas detector head

6. Installation and Wiring

6-1 How to Install the Indicator and Alarm Unit

The equipment can be hang on the wall or embedded.

⚠ WARNING

The indicator and alarm unit is not an explosion-proof construction. Install it in a non-hazardous area.

⚠ CAUTION

- The indicator and alarm unit must be installed in a place where someone is always present and is easy to read so that taking countermeasures and notifying others in case of an alarm is possible.
- Do not place the indicator and alarm unit in a place with vibration, electric noise, or corrosive gas. Avoid places with a high temperature or humidity as well.

MEMO

As to the gas detector to be connected, refer to its instruction manual.

(1) How to install on the wall

Make holes on the wall as shown in Fig. 6

If the equipment has a backup power source, attach two mounting plates on the top and bottom of the equipment.

Align the anchors with the holes then insert a bolt in the upper hole.

Insert it in the hole on top of the equipment, insert the other bolt in the bottom hole, then tighten both bolts.

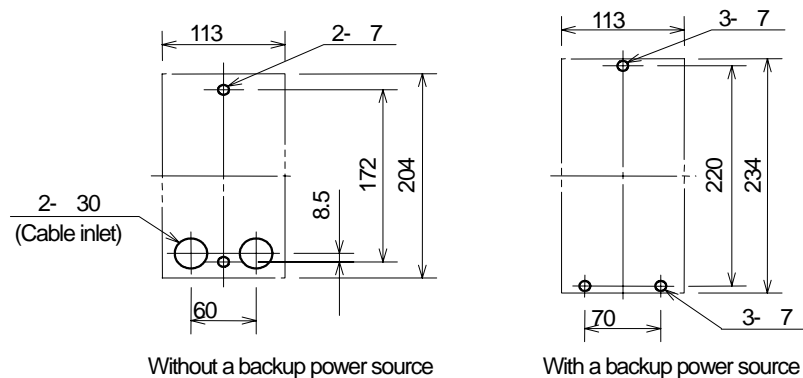

Fig. 6 Dimensions for Hanging the Equipment on the Wall

MEMO

- Size of mounting holes is different if the equipment has a backup power source.
- If the equipment has no backup power source, a cable can be connected from the back and bottom of the equipment. If the equipment has a backup power source, a cable can be connected only from the bottom.
- Leave a 30 cm space under the equipment's body for maintenance work. If the equipment has a backup power source, also leave a 30 cm space on the right side of the equipment for changing batteries.

(2) How to embed on a panel

Cut out a rectangular opening in the panel as shown in Fig. 7.

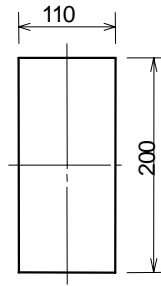

Fig. 7 Dimensions to Cut a Panel

Insert the equipment into the opening from front.

Attach the backplate on back of the equipment using the attaching screws as shown in Fig. 8. Then, fasten it to the panel with fixing screws. The equipment can be attached to a 1.6 to 6 mm thick panel.

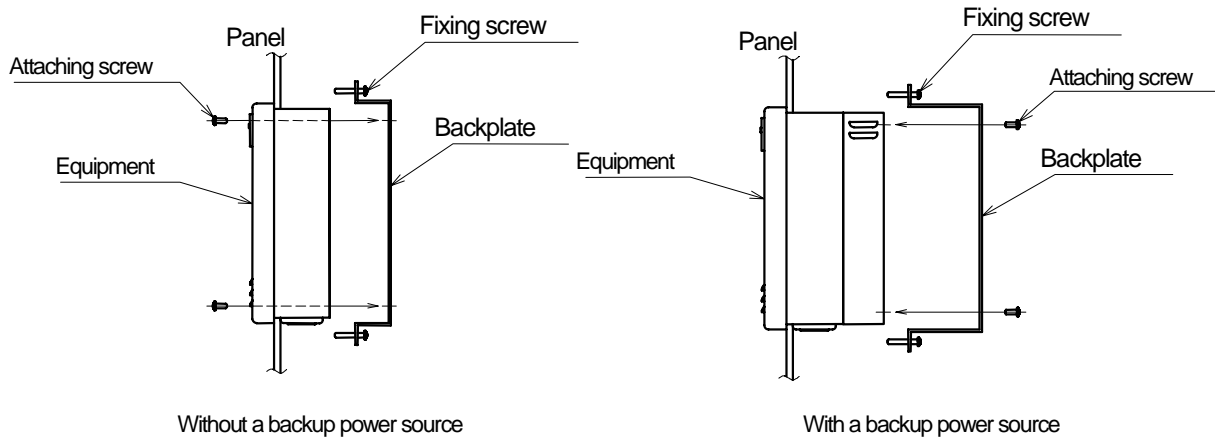

Fig.8 Embedding on a Panel

MEMO

Leave a 30 cm space under the equipment's body for maintenance work. If the equipment has a backup power source, also leave a 30 cm space on the right side of the equipment for changing batteries.

6-2 How to Install the Gas Detector

⚠ CAUTION

- The gas detector must be handled with care to avoid damaging the explosion proof construction.
- Do not install the Gas detector in locations listed below:
 - Location where the ambient temperature may drop lower than -30°C or exceed 40°C .
 - Location where dew condensation may occur.
 - Location where it could be exposed to direct water.
 - Location where corrosive gases may exist.
 - Location where get sunshine directly.
 - Location where the ambient temperature could change drastically.
 - Location where nearby a source of electrical noises.(high frequency, magnetic noises)
- Do not install the Gas detector in an atmosphere contaminated with silicon compounds, as silicon could poison and/or impair the sensitivity of the sensor.
- The gas detector should be installed in a location free from vibration.
- Avoid severe shocks and /or mechanical impact to the gas detector.
- When the gas detector is to be installed in an outside location, make sure to use a rain protective cover or cap.
- Use Auto drain function (optional item) when use the Suction type detector in a location where the detector could be watered.
- The height of the installation of the detector head is an important factor and related to the gas to be detected, refer to table below.

Kind of gas	Installation height	Remarks
Gases heavier than air ,such as LPG	About 10cm above the floor level	For maintenance purpose allow at least 7cm space from floor level
Gases lighter than air, such as H ₂ ,CH ₄ ,town gas, natural gas.	Near the ceiling	Select a location where maintenance can be easily conducted.

(1) Suction type gas detector

Use Suction type gas detector head in a location where is hard to access for maintenances such as inside a Pit or Duct as well as a location where the gas detector head could be watered.

• Installation

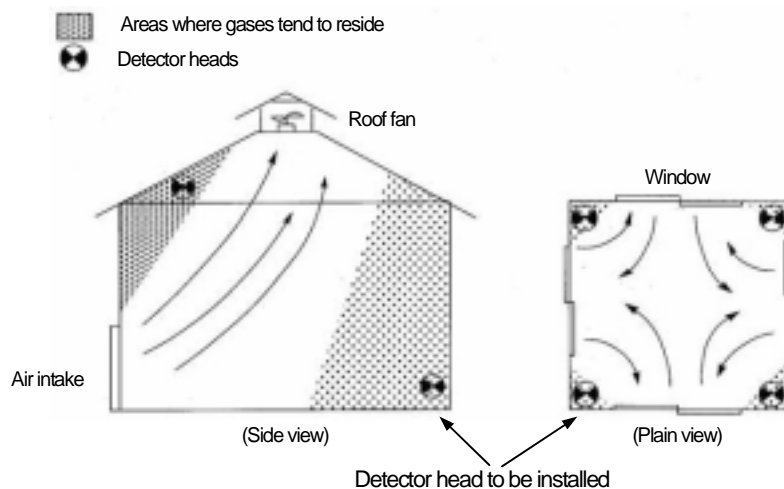

Fig.9 Diffusion type gas detector head

• **How to install the fixing plates**

Put the gas detector head between the fixing plates (Saddle and Stand) and tighten the pan-head screw to fix.

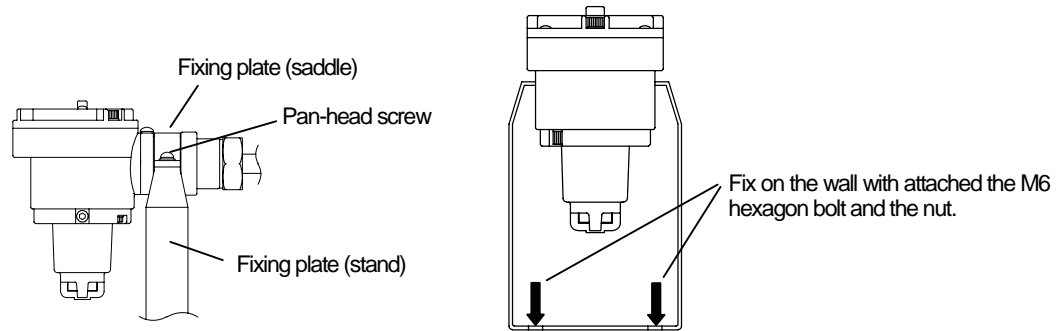

Fig.10 How to install the fixing plate

• **How to install the rainproof cover (optional item) and rainproof cap(optional item)**

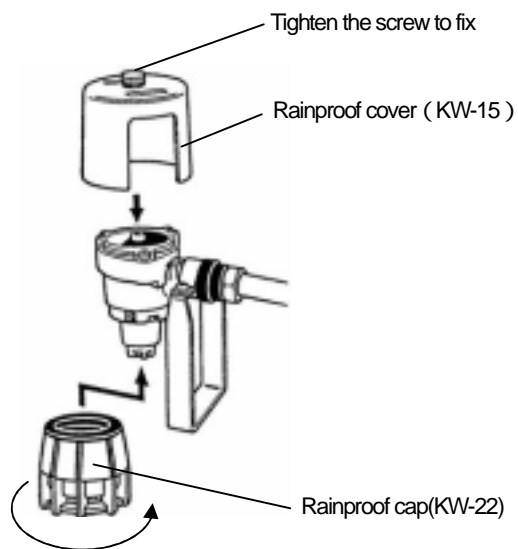

Fig.11 KW-15、KW-22 installation

(2) Suction type gas detector head

Suction type gas detector should be used in locations as follows.

- Inside a piping pit or location where is shut tightly.
- Furnace sampling
- Location where the ambient temperature is high or low
- Location where is high

Use 6 ×4 pipe work for the Suction type gas detector head and the length should be 30m or less. And the gas detector head should be installed in a location where is easy to access for maintenance.

• Example : locations to install



Fig.12 Example - location to install Suction type gas detector head

CAUTION

Sample gas collector should be installed at high location where is free from sucking water.

• Installation for Rainproof cover(PW-51)

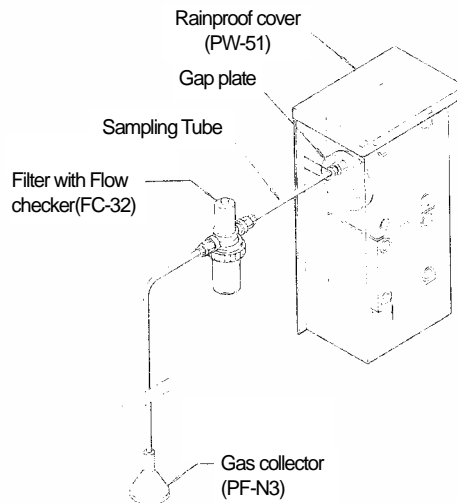

Fig. 13 Example - installation for PW-51

6-3 Wiring Method

Refer the gas detector's instruction manual as well.

WARNING

- Turn OFF the indicator and alarm unit's power before opening the cover of the gas detector. Opening the cover when the power is on may cause a fire.
- Ground the equipment's main body and gas detector.

CAUTION

- Make sure that terminal codes of the indicator and alarm unit side and gas detector side are correct.
- Use shielded cables and wire them separated from the power line as much as possible.
- Concerning the external wiring work for intrinsically safe explosion proof, refer to "Safety Guidelines for Plants' Electric Equipment."

(1) Wiring of power source

Prepare a circuit breaker to connect the power source to the indicator and alarm unit.

(2) Connecting to the gas detector

Use a cable such as 600V vinyl insulated power line(IV),VCT or CVV(0.75-2mm²).The wiring length should be as follows.

- 0.75mm² cable: within 200m
- 1.25mm² cable: within 600m
- 2.00mm² cable: within 1Km

(3) Connecting the external alarm contact

CAUTION

- Use the external alarm contact only for external alarm equipment and alarm indicators.
- Make sure that load current and voltage do not exceed the contact's capacity.
- If you control interlock, etc. using this equipment's external alarm contact, we are not responsible for any injuries or damages caused by it.

First alarm contact	1c dry contact (AC100V 2A load resistance)	COM	ZA1	ZB1
Second alarm contact	1c dry contact (AC100V 2A load resistance)	COM	ZA2	ZB2
Trouble alarm contact	1c dry contact (AC100V 2A load resistance)	COM	TA	TB
Buzzer contact	1a dry contact (AC100V 2A load resistance)	COM	BZ	
Terminal for external alarm stop (AS) and external reset (AR)		AS	AR	N

Alarm can be stopped or reset externally by connecting an external switch.

(4) Connecting the analog output terminal

Gas concentration around the gas detector can be continuously monitored and recorded by connecting a recorder to the analog output terminal. There are G(+) and H(-) terminals on the terminal block. Standard output is 4-20 mA. Input resistance of the recorder should be 500 or less.

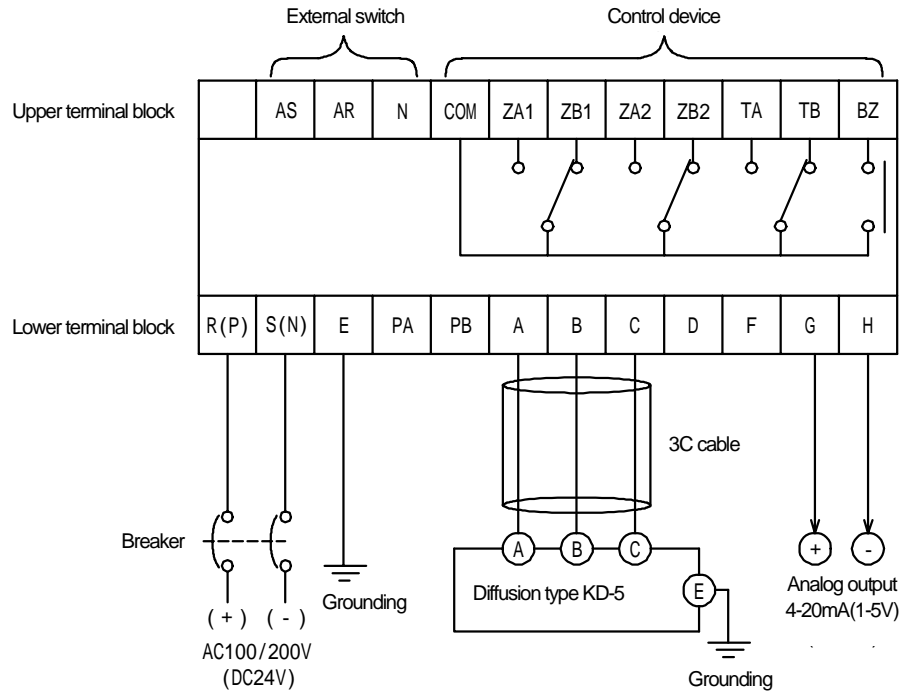

Fig. 14 Circuit (Diffusion type gas detector head)

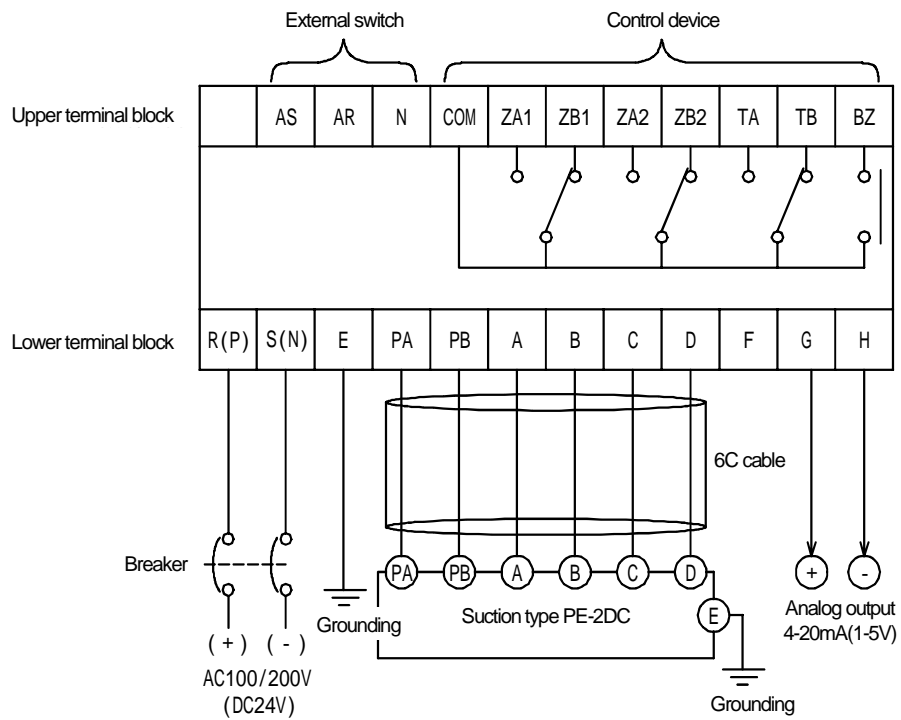

Fig.15 Circuit(Suction type gas detector head)

7. Operating Instructions

7-1 Notes to Users

CAUTION

- Make sure that all parts are correctly connected before turning on the power. Check that the terminals of the gas detector and indicator and alarm unit are correctly connected.
- Do not connect a load to the external alarm contact that exceeds the rated capacity.

7-2 Procedures

(1) Turning ON the power

Turn ON the Power switch. If the equipment has a backup power source, turn ON the Battery switch as well. Gas concentration indicator displays gas concentration and first and second preset alarm values. The Power lamp blinks green to show that the equipment is warming up. The Power lamp stops blinking and lights up green and normal operation starts. Warming up takes about 180 seconds.

(2) Gas sensor signal confirmation

Connect Tester to a gas sensor current signal terminal and measure the terminal voltage. A terminal to check gas sensor current has its built in 1 resistance (for example, it measures 180mA when a terminal voltage is 0.18 V). Since gas sensor current varies depending on sensors, always check it with test certificate supplied. Gas sensor current are adjusted at the factory and do not need adjusting at work sites. However if necessary, adjust it by turning the gas sensor adjustment volume (CURR).

(3) Zero adjustment

CAUTION

- Make sure that there is no gas around the gas detector before carrying out zero adjustment. If zero adjustment is carried out when there is gas around the gas detector, the indicator cannot indicate correct values.

MEMO

- When the equipment is kept for long time (delivery from the factory to the power on), it may take time to get the indication value on the indicator stable.
- The hot-wire semiconductor sensor mounted on this detector head is very sensitive, and base value changes by the existence of interference gases. Therefore, please adjust the base value slightly higher than 0 value. (except the equipment with linearizer)

After approximately 1 week from the power on, the indicator indication value shall be stable. Then, carry out the zero adjustment and span adjustment. Always start from the zero adjustment first.

1) Correction by the auto zero function (the equipment with linearizer only)

The reading is automatically corrected to zero by pressing the button. Use this adjustment daily for minor zero point corrections. → Refer to 7-6 (1).

2) Analog zero adjustment

Adjust zero by turning the zero adjustment volume for trial run or after replacement of the gas sensor. Use this method for most zero adjustments. → Refer to 7-6 (2).

3) Zero suppression mode (the equipment with linearizer only)

The indicator sometimes flickers when indication jumps one dot or so because of a small amount of gas around the gas detector. In this event, turn ON Function Switch 4 to select zero suppression mode and eliminate flickering of the indicated value. → Refer to 7-3 (6).

(4) Setting alarms

Alarm value is set as you specified at the time of delivery. If you want to change it, follow the procedures below.

Confirm that it is under the normal mode (Mode Switch 0) then press the Enter key.

Message window displays **AP 1**. Use the Alarm Setting keys () to change the first preset value.

Press the Enter key and the message window displays **AP 2**. Use the Alarm Setting keys () to change the second preset value.

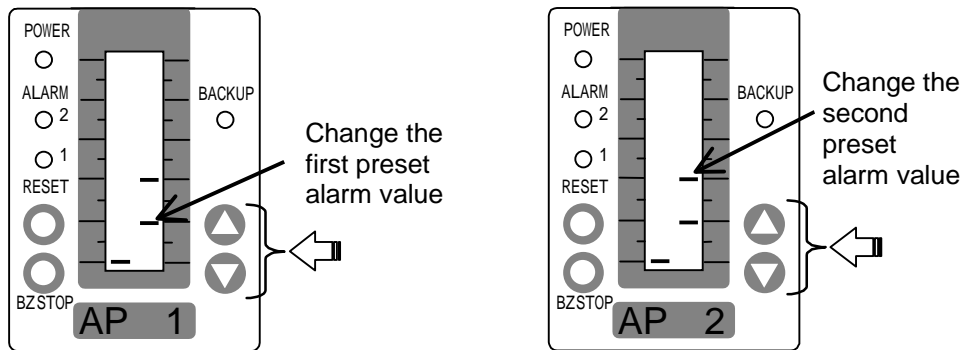

Press the Enter key again to complete the change of preset alarm value. Message window disappears and normal operation starts.

(5) Buzzer volume

1) Adjusting the buzzer volume

Turning down the SOUND volume control can lower buzzer volume. The sound is set at max at the time of delivery.

⚠ CAUTION

Keep the sound at max unless there is a particular reason for lowering it

(6) Equipment with a backup power source

The equipment with a backup power source has a function to check the battery's life. Follow the procedures below to check the battery's life.

Confirm that normal mode (Mode Switch 0) is selected then press the Battery Test Switch down for five seconds. The Backup lamp blinks red and message window indicates the battery voltage.

MEMO

- The equipment has a function to check the battery's life. Use this function during monthly inspections, etc.
- Battery test is only a simple test. To find out the battery's actual life, turn OFF the Power switch and carry out a discharge test.
- Replace battery every three years.
- The Battery Test key cannot be used in maintenance mode 1 and 2. Use the key in normal mode.

(7) Checking analog output

Terminal block **G** and **H** can output 4-20 mA (1-5V).

Connect a tester to terminal block G and H. Adjust the indicated value at zero using the Test control while pressing down the Test button. Check output on the tester. You do not need to adjust if it reads 4 mA (1V).

If it is off, adjust by turning Analog Output Adjustment control (L).

Adjust the indicated value at full scale using the Test control while pressing down the Test button. Check output on the tester. You do not need to adjust if it reads 20 mA (5V). If it is off, adjust by turning Analog Output Adjustment volume (H).

Repeat procedures 1 and 2 several times until 4-20 mA (1-5V) is read.

7-3 Operation of the equipment

(1) When gas is detected

When gas concentration around the gas detector becomes high and the reading of the gas concentration indicating bar graph exceeds the first preset alarm value, the first Alarm lamp blinks and an alarm sound (four short beeps) is heard. When the reading exceeds the second preset alarm value, the second Alarm lamp blinks. At the same time, the peak hold value blinks on the indicator.

(2) When the Buzzer Stop (BZ STOP) key is pressed

An alarm sound stops and the blinking Alarm lamp on the indicator unit lights up. Peak hold is still indicated in this state.

When using an external alarm stop terminal, you can stop the buzzer using an external switch.

(3) When the Reset key is pressed

When the Reset key is pressed after the buzzer is stopped and the reading lowers to below the preset alarm value, the Alarm lamp and peak hold go off.

When using an external reset terminal, you can reset using an external switch.

MEMO

Reset does not work by pressing the Reset key before operating the BZ STOP key.

(4) In case of a failure

1) When the gas detector is out of order

The Power lamp lights up orange, an alarm sound (four short beeps) is heard, and message window displays the type of the failure.

(Failure E: Sensor failure, H: Sensor heater wire failure, F: Flow decline)

2) When the Buzzer Stop (BZ STOP) key is pressed.

When the BZ STOP key is pressed, the alarm sound stops.

3) After the failure has been fixed

The Power lamp changes from orange to blinking green and the equipment goes into warming up state. After warming up, it returns to its normal state.

(5) Equipment with a backup power source

1) In case of a power failure

The Backup lamp blinks red and battery starts supplying power to the equipment.

2) When battery voltage lowers below the final voltage

The battery automatically stops discharging power and the equipment stops entirely.

3) When power is recovered

The Backup lamp goes off and the equipment returns to its normal operation. When power is recovered after the equipment stops because of over discharge, the equipment starts operating from warming up state.

(6) Function switches

⚠ CAUTION

If you change setting for function switches, the equipment cannot perform as it is supposed to, for example, alarm does not go off even when there is gas leakage. Do not change setting unless you completely understand features of Function switches.

The equipment's Function switches (No. 10 on Fig. Dimensions of the Indicator and Alarm Unit in 5-1)

Function switch no.	Function	OFF	ON
1	Alarm sound	N/A	Always ON
2	Alarm sound ON/OFF	ON	OFF
3	Ten second alarm delay ON/OFF	OFF	ON
4	Zero suppression function ON/OFF	OFF	ON
5	Self-retention / Auto-restore	Self-retention	Auto-restore
6	Trouble alarm : normally open / close	Normally open	Normally close
7	Heater disconnection alarm ON/OFF	ON	OFF
8	Flow decline alarm ON/OFF	ON	OFF

7-4 When an Alarm Occurs

⚠ WARNING

In case of an alarm, carry out your predetermined measures for gas leakage.

MEMO

- When gas leaks indoors, open windows and doors for better ventilation.
- Use our Gas Leak Detector XP-702S / XP-703D to efficiently find where the gas is leaking from.

7-5 How to replace Batteries (when the equipment has a backup power source)

⚠ CAUTION

- Replace two batteries at the same time.
- Do not catch the harness when attaching the battery cover.

Detach the battery cover on the right side of the backup power source unit.

Detach the battery connector and take out the batteries.

Insert new batteries and attach the connector.

Put the battery cover back.

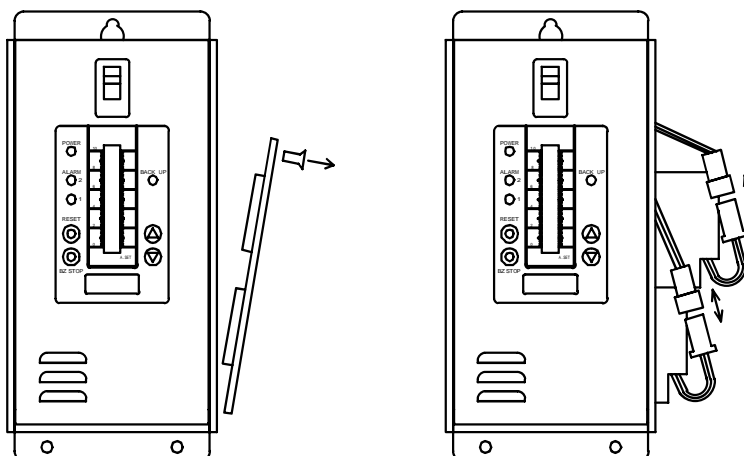

Fig. 16 How to replace the Batteries

7-6 Maintenance Function

WARNING

- When adjustment in a mode is completed, always set the Mode switch at zero to return to normal mode. If the switch is left at other mode, the equipment cannot alarm gas leakage correctly.
- Message window displays “preset value” and “_____” alternately during maintenance mode to prevent you from forgetting to return to normal mode after adjustment.
- Do not change the setting for modes 3 to 9. If the setting is changed, the equipment cannot properly alarm you of a gas leakage.

CAUTION

Re-check the following items in normal mode after zero and span adjustments are performed in maintenance mode 1 and maintenance mode 2.

The zero point is correctly indicated at zero.

The gas concentration is correctly indicated when calibration gas is applied.

MEMO

- Use auto zero and span adjustment daily for minor zero point and sensitivity corrections, and use analog zero and span adjustment for normal corrections.
- A precision screwdriver (blade diameter: 1.3 mm) is required to turn the zero and span adjustment dials.

NV-100H has maintenance mode function. Select a mode using the Mode switch to use each function. Functions of modes are described in the following table.

Mode switch no.	Mode name	Function	Remarks
0	Normal mode	Normal state to monitor gas leakage	<ul style="list-style-type: none"> • Use the equipment in this mode.
1	Maintenance mode 1	Auto zero and span adjustment	<ul style="list-style-type: none"> • Press the button to adjust the zero point and span automatically. • Use this adjustment for minor zero point and sensitivity corrections. • Alarm contact and buzzer contact do not operate.
2	Maintenance mode 2	Analog zero and span adjustment	<ul style="list-style-type: none"> • Turn the dial to adjust the zero point and span. • Use this method for most adjustments. • Cancel auto zero and span function. • Cancel zero suppression function. • During pressing the Enter key, linearization is cancelled. • Alarm contact and buzzer contact do not operate.
3-9	-	Only used for adjustment at factory	<ul style="list-style-type: none"> • Do not use them.

(1) Zero and span adjustment without linearizer specifications

MEMO

Use the analog zero and span adjustment method to adjust non-linearizer models.

1) Analog zero adjustment (Maintenance mode 2)

Set the Mode switch at 2 to select maintenance mode 2.

Press down the BZ STOP key until the Power lamp goes off.

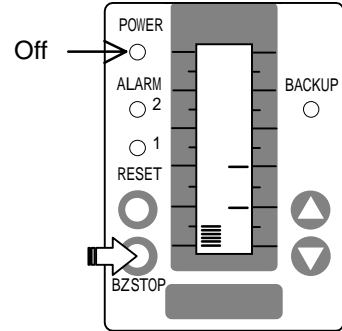
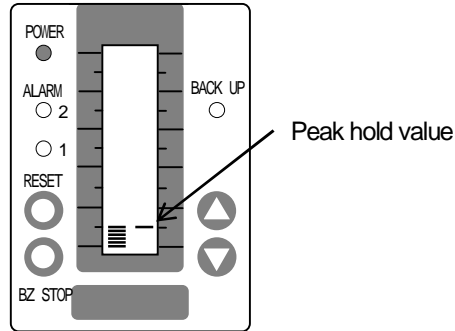

The Power lamp lights up again and the auto zero adjustment value is reset.

Make sure that there is no gas around the gas detector then turn the zero adjustment volume (ZERO) to set the indicated value to 1.0.

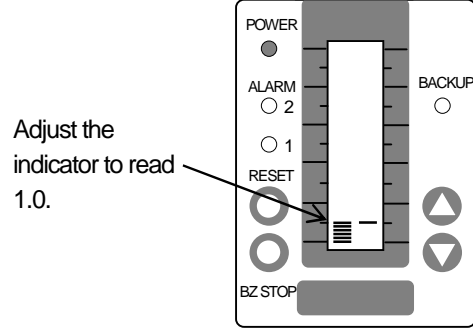
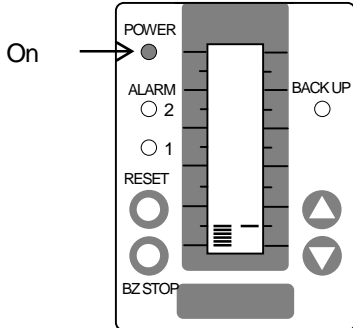

Set the Mode switch at zero to return to normal mode.

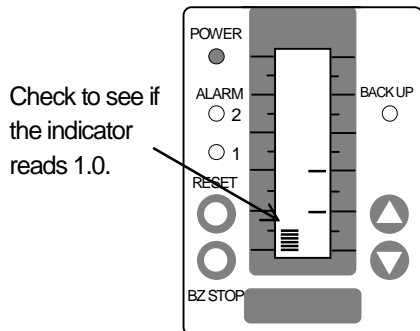

2) Analog span adjustment (Maintenance mode 2)

CAUTION

Always perform analog zero adjustment before doing analog span adjustment. Otherwise the span cannot be adjusted properly when the analog span adjustment is performed.

Set the Mode switch at 2 to select maintenance mode 2.

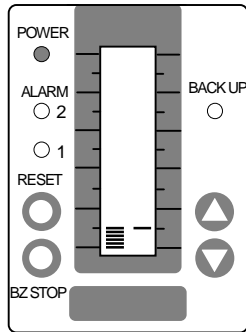

Press down the RESET key until the Power lamp goes off.

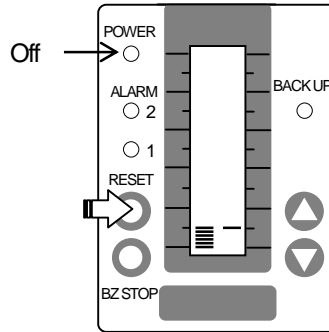

The Power lamp lights up again and the auto span adjustment value is reset.

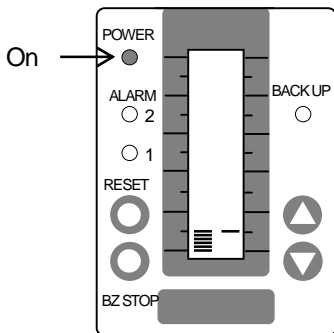

Set the Mode switch at 1 to select maintenance mode 1.

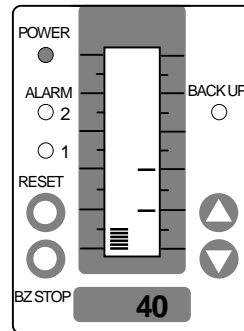

Confirm that the zero point is at 1.0 and apply calibration gas to the gas detector for a minute.

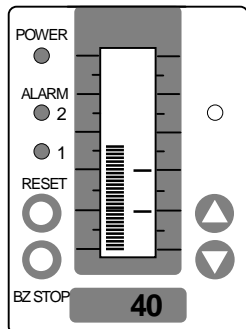

Set the Mode switch at 2 to select maintenance mode 2.

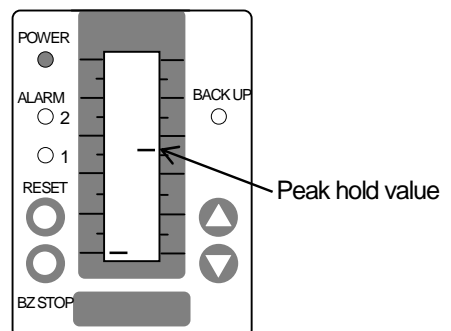

Press the test button and simultaneously turn the test volume until the reading matches the peak hold value.

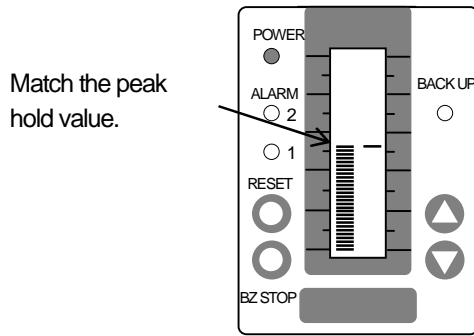

Then adjust the span adjustment volume (SPAN) and adjust the indication value to the calibration gas concentration.

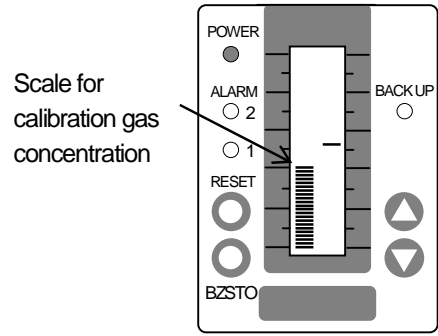

Release the test button and confirm that the indicated value indicates 1.0.

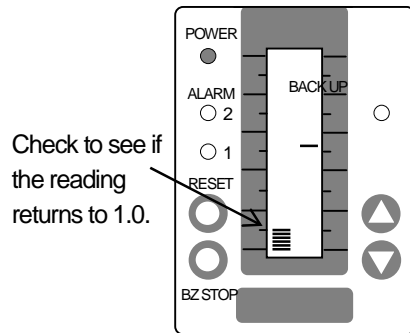

Press down the test button and adjust the indication value to full scale.

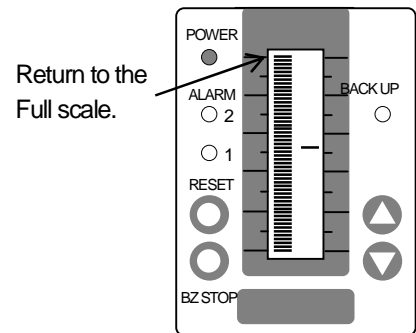

Set the Mode switch at zero to return to normal mode.

Apply the calibration gas and check to see if the gas concentration is indicated correctly.

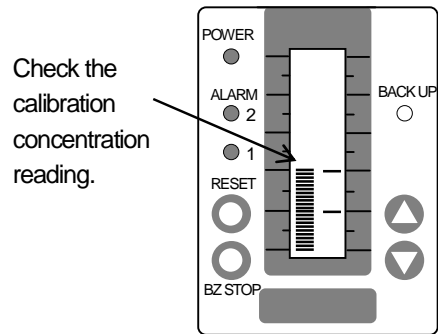
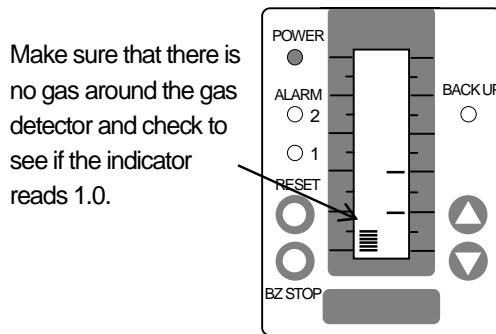

CAUTION

Note that a gas leak alarm and external output will be generated when calibration gas is applied in normal mode.

(2) Zero and span adjustment for models with linearizer specifications

MEMO

There are two ways to adjust models with linearizer specifications: auto zero and span adjustment or manual zero and span adjustment. Use auto zero and span adjustment daily for minor zero point and sensitivity corrections, and use analog zero and span adjustment for normal adjustments.

1) Auto zero adjustment (Maintenance mode 1)

Set the Mode switch at 1 to select maintenance mode 1.

Make sure that there is no gas around the gas detector then press down the BZ STOP key until the Power lamp goes off.

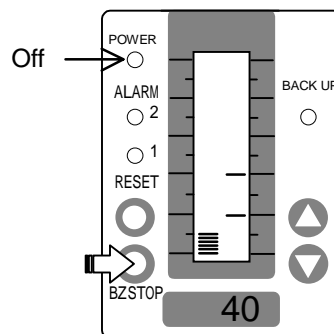
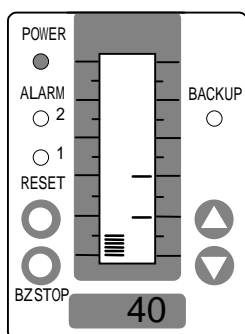

The Power lamp lights up again and the indicated value is automatically corrected to zero.

Set the Mode switch at zero to return to normal mode.

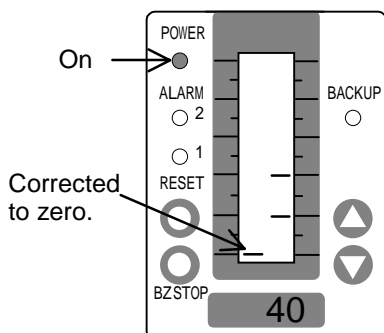

Check that the reading returns to zero

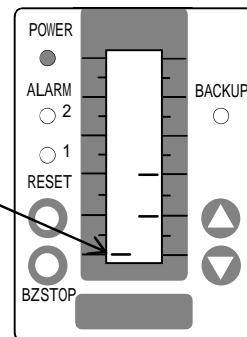

MEMO

If the indicated value is outside the auto zero adjustment range when the BZ STOP key is pressed, the message window will display a blinking "Err" indication and auto zero adjustment will be impossible. If this occurs, carry out analog zero adjustment in maintenance mode 2.

2) Auto span adjustment (Maintenance mode 1)

Set the Mode switch at 1 to select maintenance mode 1.

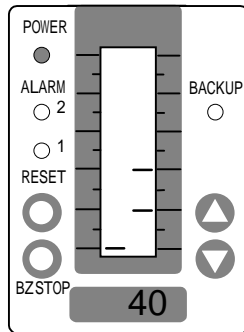

Set the auto span preset value (any number between 10 and 100) using the Alarm Setting keys ().

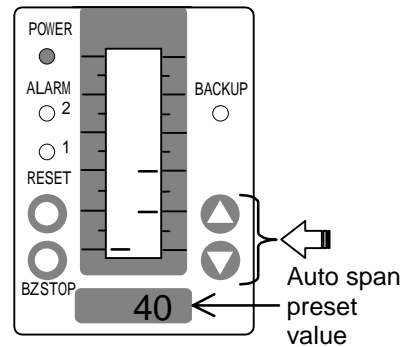

Confirm that the zero point is at zero and apply calibration gas to the gas detector for a minute.

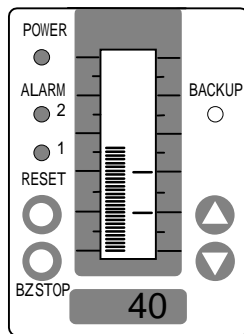

If peak hold value does not match calibration gas concentration, press down the Reset key until the Power lamp goes off.

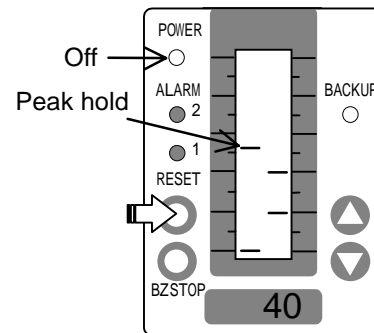

The Power lamp lights up again and the peak hold value is automatically corrected to the auto span preset value.

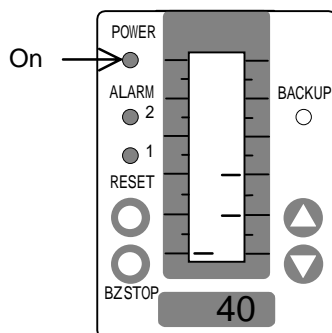

Set the Mode switch at zero to return to normal mode.

Make sure there is no gas around the gas detector and check to see if the indicator reads 0.

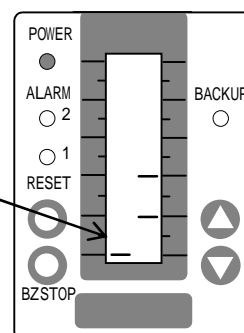

Finally apply the calibration gas and check to see if the calibration concentration is indicated correctly

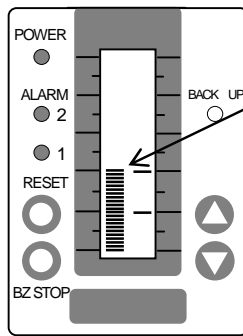

Check the calibration concentration.

⚠ CAUTION

Note that a gas leak alarm and external output will be generated when calibration gas is applied in normal mode.

MEMO

If the indicated value is outside the auto zero adjustment range when the RESET key is pressed, the message window will display a blinking "Err" indication and auto zero adjustment will be impossible. If this occurs, carry out analog span adjustment in maintenance mode 2.

(3) Analog zero and span adjustment (Maintenance mode 2)

MEMO

- The maintenance mode 2 shows indications with the auto zero and span functions and the zero suppression function cancelled. Therefore, the indicated values in this mode may differ from those in normal mode.
- Always reset auto zero and span adjustment values during analog zero or span adjustment. If you fail to do so, zero and span adjustment cannot be carried out correctly.
- Indicated values with linearization cancelled are displayed while the Enter button is being pressed.

Set the Mode switch at 2 to select maintenance mode 2.

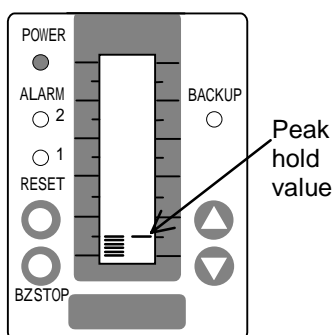

Press down the BZ STOP key until the Power lamp goes off.

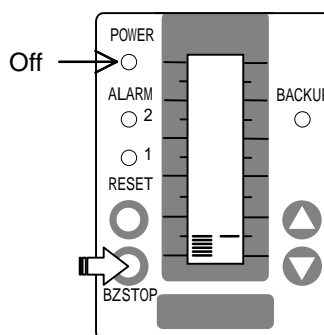

The Power lamp lights up again and the auto zero adjustment value is reset.

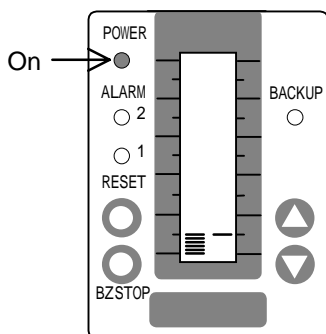

Make sure that there is no gas around the gas detector. Press the enter key and simultaneously turn the zero adjustment volume (ZERO) to set the indicated value on zero.

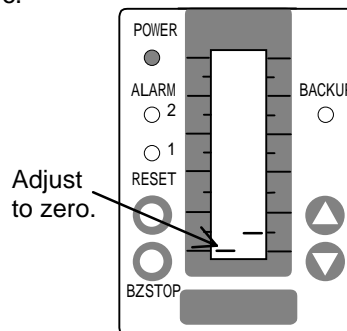

Set the Mode switch at zero to return to normal mode.

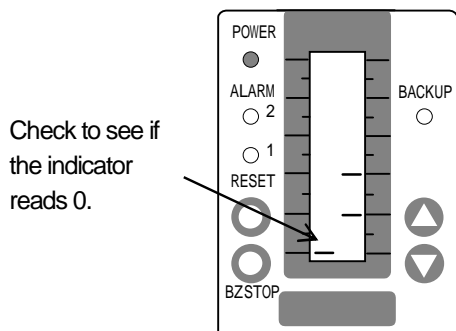

(4) Analog span adjustment (Maintenance mode 2)

CAUTION

Always perform analog zero adjustment before doing analog span adjustment. Otherwise the span cannot be adjusted properly when the analog span adjustment is performed.

Set the Mode switch at 2 to select maintenance mode 2.

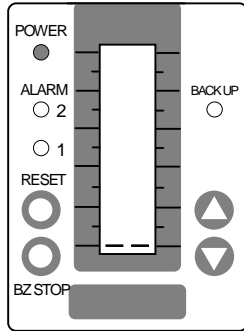

Press down the reset key until the Power lamp goes off.

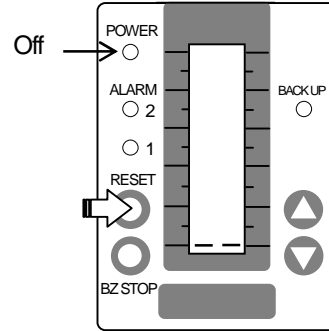

The Power lamp lights up again and the auto span adjustment value is reset.

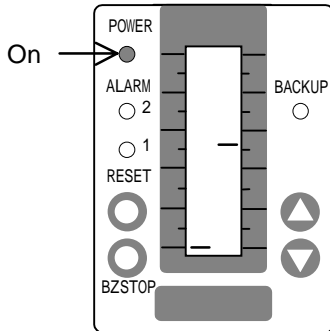

Set the Mode switch at 1 to select maintenance mode 1.

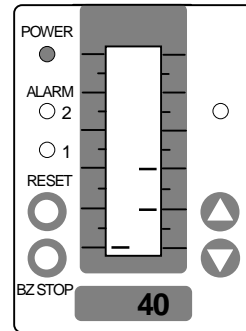

Confirm that the zero point is at zero and apply calibration gas to the gas detector for a minute.

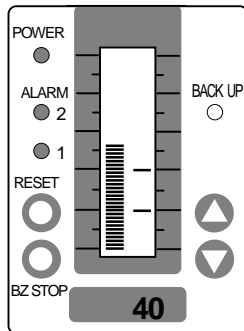

Set the Mode switch at 2 to select maintenance mode 2.

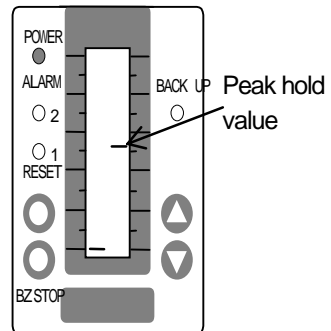

Turn the test volume while pressing the test button to match the indicated value to the peak hold value.

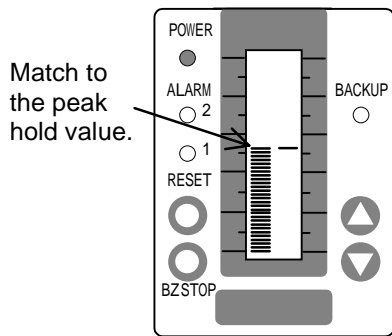

Then, turn the span control (SPAN) to match the indicated value to the calibration gas concentration value.

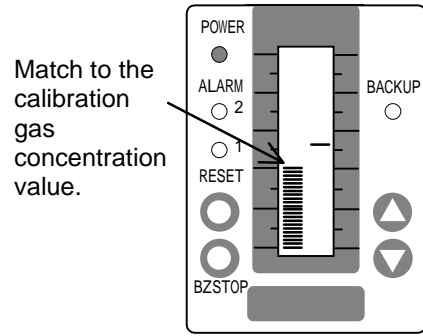

Release the test button and check that the indicated value returns to zero.

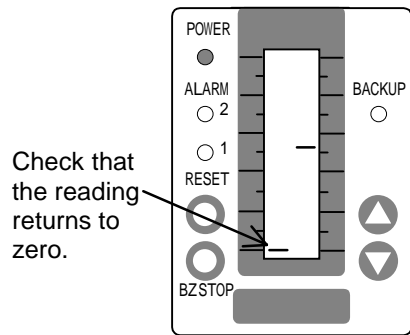

Turn the test volume while pressing the test button to return the indicated value to the full scale.

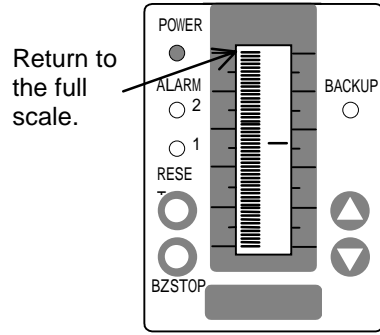

Set the Mode switch at zero to return to normal mode.

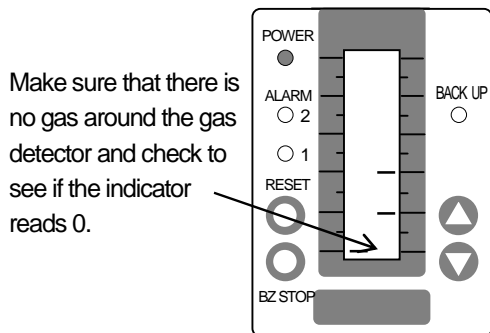

Apply the calibration gas and check to see if the gas concentration is indicated correctly.

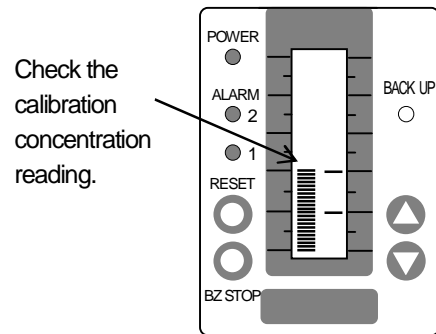

CAUTION

Note that a gas leak alarm and external output will be generated when calibration gas is applied in normal mode.

8. Maintenance and Inspections

Maintenance and inspections are very important for the equipment because the purpose of the equipment is to secure safety. Maintenance and inspections are the users' responsibility. We can offer regular inspections if you make a maintenance contract with us. (Contact our dealer / agency for detailed information.)

8-1 Regular Inspections (Inspections that the users are responsible for) (See Table 1.)

(1) Regular inspection (daily)

Zero point check

POWER lamp check

Flow inspection (for Suction type gas detector only)

(2) Monthly inspection

Performance test by pressing the Test button

Inspection of the backup power supply unit (when the equipment has backup power supply)

(3) Inspections that should be carried out every two or three months

Performance test using actual gas

Visual inspection

Situation around the gas detector

Items to be inspected regularly and the inspection method
Table 1

Items to be inspected	Inspection method
Zero point check	<ul style="list-style-type: none"> • Make sure that there is no gas around the gas detector then check that the bar graph on the indicator indicates zero.
POWER lamp check	<ul style="list-style-type: none"> • Check that the POWER lamp (green) on the indicator unit is on.
Flow inspection (for Suction type gas detector only)	<ul style="list-style-type: none"> • Check that the flow checker's filter float has not gone down. It should be 0.7L/min or more. If the float has gone down, check if the filter is clogged.
Performance test by pressing the TEST button	<ul style="list-style-type: none"> • Press the TEST button on the indicator unit and check that the bar graph on the indicator operates, the ALARM lamp (red) on the indicator unit and the main ALARM lamp (red) on the alarm unit blink, and an intermittent buzzer is heard from the alarm unit. <div style="border: 1px solid black; border-radius: 15px; padding: 10px; text-align: center;"> <p>⚠ CAUTION</p> <p>Note that connected the external alarm or lamp go on when the TEST button on the indicator unit is pressed.</p> </div>
Backup power source device inspection (Equipment with a backup power source device only.)	<ul style="list-style-type: none"> • Refer to 7-2(6) battery's life check

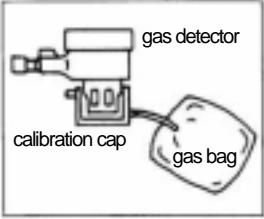
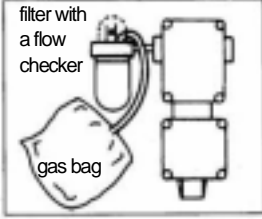
<p>Performance test using actual gas</p>	<ul style="list-style-type: none"> • Apply the calibration gas to the gas detector and check if an alarm goes off. • Check that the ALARM lamp (red) on the indicator unit blinks and an alarm sound is given. (Refer to 8-3 for how to make calibration gas.) <p style="text-align: center;">How to apply calibration gas</p> <div style="display: flex; justify-content: space-around;"> <div style="text-align: center;">  <p>a. Diffusion type gas detector</p> </div> <div style="text-align: center;">  <p>b. Suction type gas detector</p> </div> </div>
<p>Visual inspection</p>	<ul style="list-style-type: none"> • Check the following visually. <ul style="list-style-type: none"> • Clogging of the rainproof cap filter (diffusion type gas detector) • Clogging and corrosion of the frame arrester (diffusion type gas detector) • Corrosion of the gas detector • Corrosion of fittings
<p>Situation around the gas detector</p>	<ul style="list-style-type: none"> • Check if there is anything blocking the diffusion or suction gas detector that is hindering the detection of gas.

8-2 Maintenance inspections (Contact our dealer / agency for the inspection.)

(1) Items to be inspected regularly and the inspection method

Carry out the following inspections at least once a year.

Table 2

Items to be inspected	Inspection method
Sensor's current inspection	<ul style="list-style-type: none"> • Refer to "7-2. Procedures" (2).
Zero point adjustment	<ul style="list-style-type: none"> • Refer to "7-2. Procedures" (3).
POWER lamp check	<ul style="list-style-type: none"> • Refer to 2 on Table 1 about daily inspection.
Preset alarm value	<ul style="list-style-type: none"> • Check that the preset alarm value mark on the indicator unit's bar graph is at the proper value. (Refer to "7-2. Procedures" (4).)
Flow inspection (Suction gas detector only)	<ul style="list-style-type: none"> • Refer to 3 on Table 1 about daily inspection.
Filter inspection (Suction gas detector only)	<ul style="list-style-type: none"> • Refer to User manual for Detector head
Span adjustment (Sensitivity inspection)	<ul style="list-style-type: none"> • Apply calibration gas(1.6 times more than the preset alarm value) to the gas detector and check the bar graph on the indicator unit.
Response time check	<ul style="list-style-type: none"> • Check how long it takes from when you start applying gas to the gas detector until and an alarm goes off. It should be within 30 seconds. * If an alarm does not go off within 30 seconds, check for clogging of sintered metals or the filter of suction type gas detector.

<p>Backup power source device inspection (Equipment with a backup power source device only.)</p>	<ul style="list-style-type: none"> • Cut off the power supply and check that the alarm and indicator unit normally operates for at least 30 minutes. Battery voltage indicated on the backup power source unit should be 23V or more after 30 minutes of operation. • If the equipment's operation stops within 30 minutes, the battery needs to be replaced with a new one. (The equipment has a function to prevent over discharge. It automatically stops before over discharge happens.) • Battery's life span is three years. Check that it has not expired. <div style="border: 1px solid black; border-radius: 15px; padding: 10px; text-align: center;"> <p>⚠ CAUTION</p> <p>Replace an expired battery or it may not work in case of a power failure.</p> </div>
--	---

8-3 Preparation of Calibration Gas (used for your actual gas performance test) – When isobutene 0.1vol%

(1) If you have a standard gas cylinder

Fill a gas bag with standard gas as shown in Fig.17. Completely vacuum the air from the bag before filling the gas because the air in the bag may cause an error of the gas concentration.

(2) If you do not have a standard gas cylinder

Make 0.1vol% (5.6%LEL) calibration gas by diluting pure gas (isobutane 99%) with the air using the calibration equipment kit.

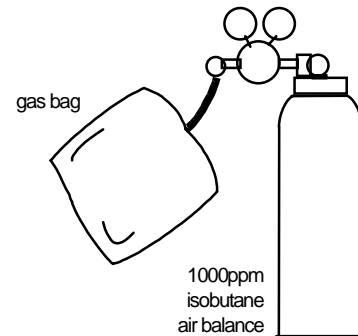

Fig. 17 Taking Standard Gas

MEMO

The calibration gas can be used to check the alarm function. Check the concentration using Gas Detector XP-311 or a similar device before using the gas for calibration of the indicator.

⚠ DANGER

Make sure that there are no flammables nearby when handling flammable gas with a concentration over LEL (lower explosive limit).

Drawing raw gas

Connect a gas bag to an isobutane 99vol% cylinder and draw a little more than you actually need.

Bend back the hose and pinch with a pinch cock so the gas does not leak from the bag.

Drawing a fixed amount of raw gas

Connect a 10ml syringe to a gas bag and draw 1ml of raw gas. (Draw a little more than you actually need then discharge the excess.)

Transferring raw gas into a quantitative pump

Connect a syringe to the inlet of a quantitative pump then pull out the pump's piston. Raw gas in the syringe is sucked into the pump. Remove the syringe and pull the piston all the way out (100ml).

Making diluted gas

Connect an empty gas bag to the outlet of the quantitative pump then push in the pump's piston.

Move the piston back and forth nine times to add air in order to make diluted gas.

MEMO

If you take 1ml of raw gas and move the quantitative pump's piston back and forth ten times (a back-and-force motion: 100ml),

$$1\text{ml}/(100\text{ml}\times 10)=0.001$$

0.1vol% diluted gas is made.

Isobutane's lower explosive limit (LEL) is 1.8vol%.

$$0.1/1.8\times 100=5.555\dots$$

5.6%LEL diluted gas is made.

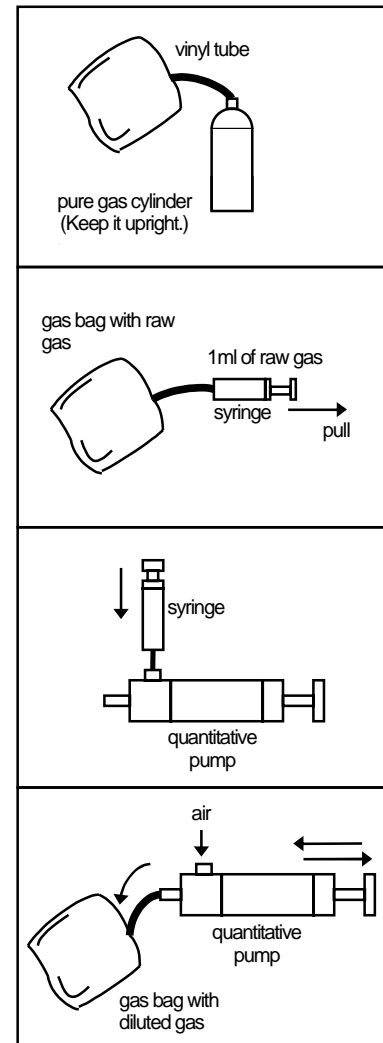

Fig. 18 Making Standard Gas from Raw Gas

(3) Calibration equipment kit (optional)

Contact our dealer / agency for a calibration equipment kit.

A kit to easily make calibration gas is also available. Please contact our dealer / agency.

(Equipment included in the calibration equipment kit differs according to detectors.)

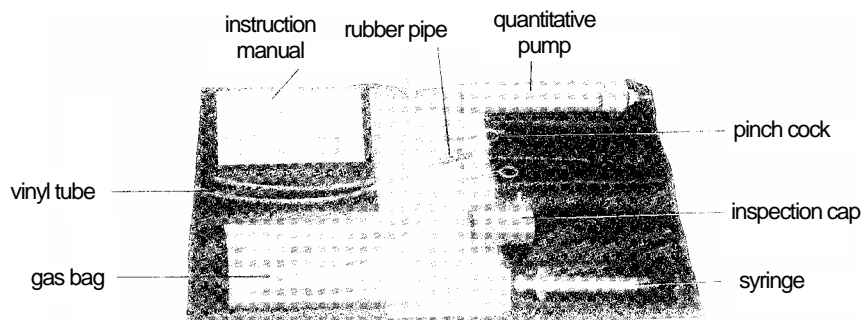

Fig. 19 Calibration Equipment Kit (for KD-5)

8-4 Replacing the Gas Sensor

⚠ WARNING

- Turn OFF the power of Indicator / Alarm unit before opening the cover of the gas detector.
- Opening the cover of the gas detector when the power is on may cause a fire.

⚠ CAUTION

- Be careful not to damage the junction where the electric compartment cover meets the terminal box on the gas detector. Damage to this area reduces the explosion-proof properties of the equipment.
- Always contact our dealer when replacing the sensor because improperly doing so may decrease the equipment's performance. Zero and span adjustment are also necessary after replacing the sensor.

(1) Replacing the sensor of the diffusion type gas detector KD-5 -N

Turn OFF the power switch and battery switch (when it is with a backup power source) on the indicator unit.

Loosen the locking screw on KD-5B with a M4 hexagon wrench.

Turn the sensor guard to the left by about 30 degrees and detach it.

Pull down the sensor unit so it comes off.

Attach a new sensor unit and turn the sensor guard to the right until it fits properly.

Fasten the locking screw with a M4 hexagon wrench.

Turn ON the power switch and battery switch on the indicator unit to start normal operation.

Carry out zero and span adjustments after replacing the sensor unit. (Refer to "5-6. Maintenance Function" (1) and (3).)

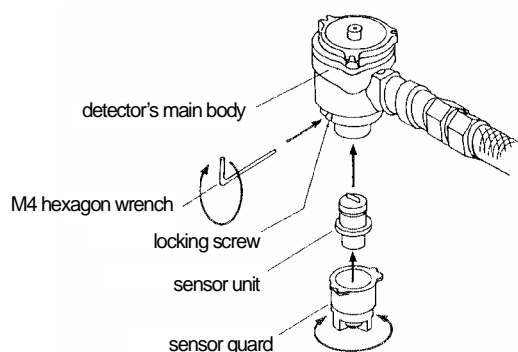

Fig. 20 Replacing the Sensor of a Diffusion Gas Detector

MEMO

Refer to the instruction manual for KD-2A, KD-3A when use gas detector head KD-2A, KD-3A

(2) Replacing the sensor of the suction type gas detector PE-2DC

Turn OFF the power switch and battery switch (when it is with a backup power source) on the indicator unit.

Loosen the four hexagon socket head bolts (M10x25) that fasten the electric compartment's cover of PE-2DC with a M10 hexagon wrench and open the cover.

Detach all crimp-style terminals of gas sensor cables and lead-in cables from the trunk terminals.

Detach the four screws (M3x15) that fasten the printed wiring board, detach the printed wiring board and gas sensor holding board, then take out the gas sensor.

Place the O ring on top of the detection compartment and attach a new gas sensor in the detection compartment. There is a black dot (•) on the gas sensor. Place the sensor so the dot faces the side where the gas comes in.

Pass the gas sensor cables through the gas sensor holding board and printed wiring board then fix them back onto the detection compartment. (Set the gas sensor holding board onto the detection compartment in the correct direction.)

Attach the crimp-style terminals of gas sensor cables and lead-in cables to the trunk terminals.

Close the electric compartment's cover then tightly fasten it with the hexagon socket head bolts (M10x25).

Turn ON the power of the Indicator / Alarm unit and carry out zero adjustment (refer to "5-2. (4) Zero adjustment") and span adjustment.

(Refer to "5-6. Maintenance Function.")

MEMO

- Make sure to use washers when attaching hexagon socket head bolts and screws.
- Return used gas sensors to us.

Color of gas sensor cable	Trunk cable no.	Color of lead-in cable
Pink→	1	←Red
Black→	2	←Black
White→	3	←White
	4	←Green

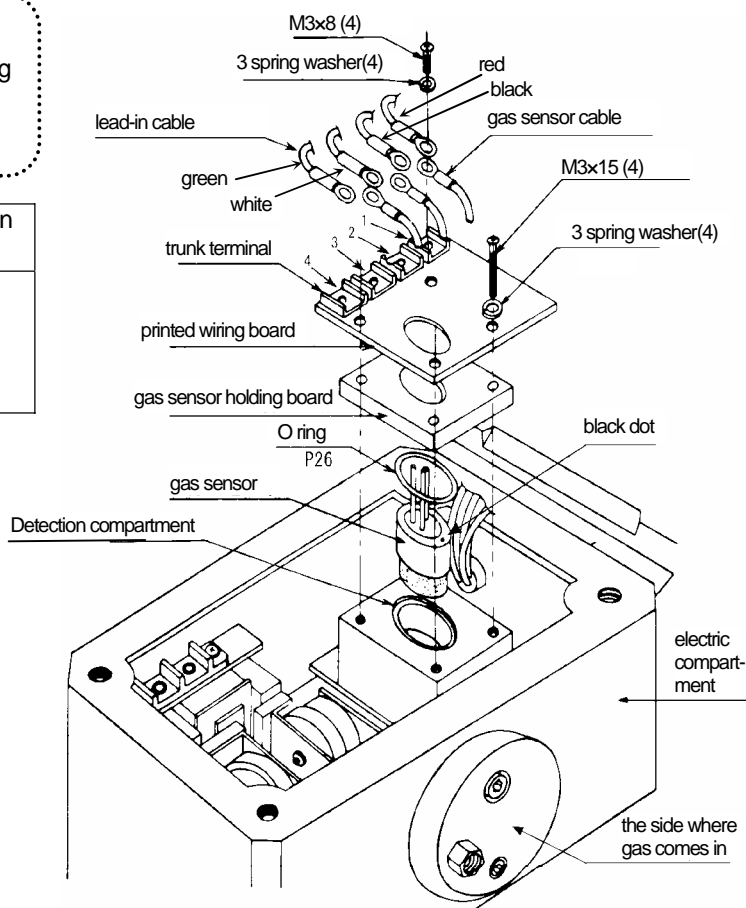

Fig. 21 Replacing the Sensor of the Suction Gas Detector

8-5 Replacing the Filter (suction type gas detector)

When the filter of a flow checker which is a part of suction type gas detector becomes dirty, replace it with a new one. If you keep using a dirty filter, it may decrease flow.

Loosen the fastening ring and detach the cup and O ring.

Detach the dirty filter by turning and twisting it.

Wash the inside of the cup with water and completely dry it.

Press a new filter in and upwards as far as it goes to attach it.

Attach the cup and O ring then fasten the fastening ring.

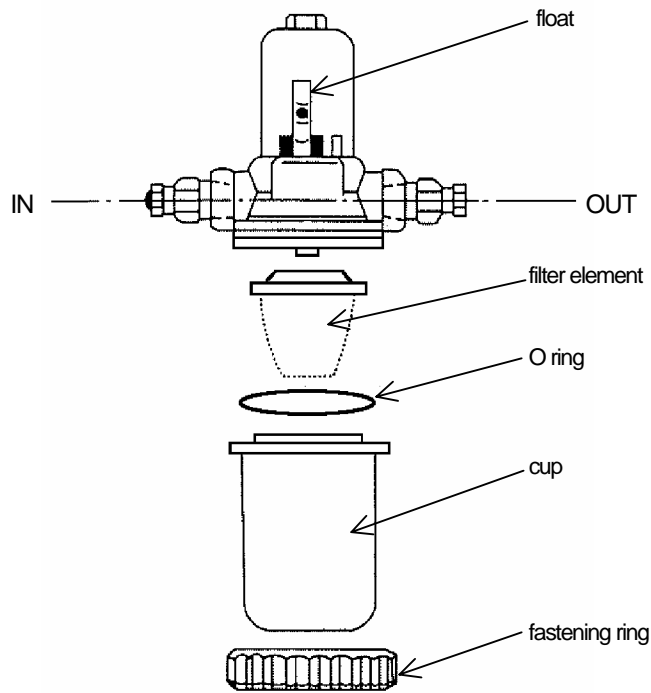

Fig. 22 Replacing the Filter of a Flow Checker FC-32

8-6 Cleaning the Gap Plate (suction type gas detector PE-2DC)

⚠ WARNING

Turn OFF the power of the main body before cleaning the gap plate in order to prevent a fire or explosion.

⚠ CAUTION

Be careful not to damage the joints of the gap plate or the side of the electric compartment. Damage to these parts decreases the equipment's explosion-proof properties.

Detach the two hexagon socket head bolts from the gap plate using hexagon wrench.
Size of the hexagon socket head bolts is different (M5 and M6).

Slowly detach the gap plate and remove three O rings (P5, P6, and TPG-6).

Wipe off dust and dirt on the gap plate and gas detector's main body with a soft cloth.

Assemble the gap plate by the opposite procedures from above.

Make sure the three O rings and spring washers are attached in their correct positions.

MEMO

If you need to detach the filter with a flow checker to carry out the above, loosen the joint to detach it.

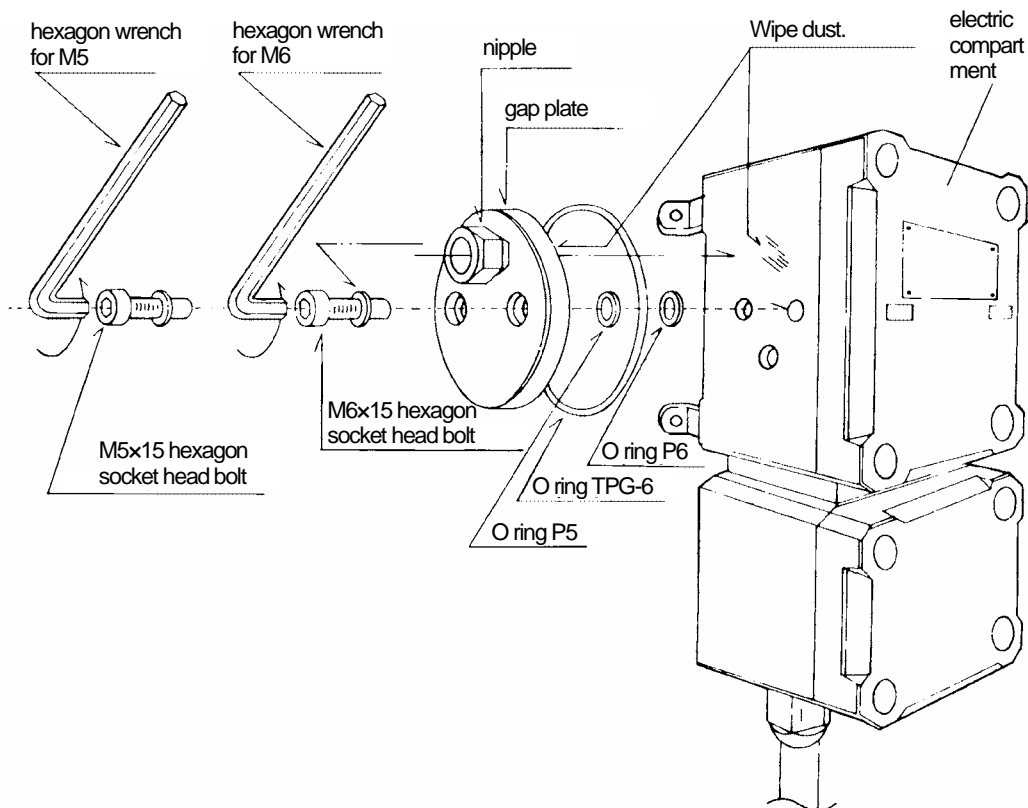

Fig. 23 Cleaning PE-2DC's Gap Plate

9. Troubleshooting

Check the following before requesting repair work.

Problem	Cause	Action	Section to refer
<ul style="list-style-type: none"> The Power lamp does not light up even after the Power switch is turned ON. 	<ul style="list-style-type: none"> Wires are not correctly connected. 	<ul style="list-style-type: none"> Check and fix wiring correctly. 	<ul style="list-style-type: none"> Refer to 6-3.
	<ul style="list-style-type: none"> Wires are not connected properly. 	<ul style="list-style-type: none"> Retighten the terminals. 	
	<ul style="list-style-type: none"> Commercial power source fuse is disconnected. 	<ul style="list-style-type: none"> Replace the fuse. 	
<ul style="list-style-type: none"> Although the Power lamp lights up when the Power switch is turned ON, gas concentration is not displayed. 	<ul style="list-style-type: none"> Mode switch is not set at zero. 	<ul style="list-style-type: none"> Set the Mode switch at zero. 	<ul style="list-style-type: none"> Refer to 7-6.
<ul style="list-style-type: none"> The Power lamp lights up orange. 	<ul style="list-style-type: none"> The equipment and the gas detector are not properly connected. 	<ul style="list-style-type: none"> Check the wiring and re-tighten the terminal. 	<ul style="list-style-type: none"> Refer to 7-6.
	<ul style="list-style-type: none"> Gas sensor failure in the detector head. 	<ul style="list-style-type: none"> Replace the gas sensor 	<ul style="list-style-type: none"> Refer to the instruction for Detector head
<ul style="list-style-type: none"> Battery voltage is low. 	<ul style="list-style-type: none"> The equipment has not been used for a long period of time. 	<ul style="list-style-type: none"> Turn on the electricity and wait until battery voltage becomes 24V or more 	<ul style="list-style-type: none"> Refer to 7-2 (6).

10. Specifications

10-1 Indicator and Alarm Unit

Model	NV-100H
Principle of detection	Hot-wire semiconductor type sensor
Gases to be detected	Combustible gases
Indicating range	As specified.
Gas concentration indicator	LCD bar graph meter with back light
Standard preset alarm value	As specified. (The value can be adjusted within measuring range.)
Alarm accuracy	Within $\pm 25\%$ of the preset alarm value in the same condition
Response time	Within 30 seconds when gas concentration is 1.6 times more than the preset alarm value (Except for delay due to length of sampling pipe.)
Alarm indication	First alarm: First Alarm lamp blinks red and a buzzer is heard. Second alarm: First and second Alarm lamps blink red and a buzzer is heard.
Trouble indication	Power lamp rights up orange and the content of the failure is indicated.
Alarm output terminal (common)	
First alarm contact	No voltage 1c contact (Contact capacity: AC100V 2A load resistance)
Second alarm contact	No voltage 1c contact (Contact capacity: AC100V 2A load resistance)
Trouble alarm contact	No voltage 1c contact (Contact capacity: AC100V 2A load resistance)
Buzzer contact	No voltage 1a contact (Contact capacity: AC100V 2A load resistance)
External reset terminal	Terminals for external alarm stop and reset
Analog output	4-20 mA (standard) 1-5 V (Option.)
Alarm delay	Delay mode can be set. (Delay time: About 10 seconds)
Power source	AC100-240V 50/60Hz (standard) DC24V (Option.)
Power consumption	Diffusion type: 12VA / 17VA (with a backup power source) Suction type: 4VA per unit to be add.
Backup power source (Equipment with a backup power source only.)	Battery: Gastight lead battery (12V0.8Ahx2) Backup time: 60 minutes or more Function to prevent over discharge: Stops discharging at the battery's final voltage. Charge time: About 12 hours
Maintenance function	Maintenance mode 1 Alarm contact and buzzer contact do not operate. Alarm sound: Buzzer. Maintenance mode 2 Alarm contact and buzzer contact do not operate. Auto zero and auto span functions are canceled. Linearization is cancelled while Enter button is being pressed.
Temperature range	0 to 40
Installation	Wall-hanged or panel-embedded
Painting color	Munsell 2.5PB7.0/1.0
Dimensions	Without a backup power source: W113 x D71.5 x H204 mm About 1.5 kg With a backup power source: W113 x D110 x H234 mm About 3 kg
Remarks	Do not use any equipment that generates electric waves such as cellular phones or radios within 30 cm of the indicator and alarm unit.

* Refer to the gas detector's instruction manual.

10-2 Gas Detector

Type	KD-5A	KD-5B	PE-2DC
Sampling method	Diffusion type	Diffusion type	Suction type
Explosion-proof structure	d3aG4	d2G4	d2G4
Operating temperature	-10 ~ 40 (no condensation)	-10 ~ 40 (no condensation)	-10 ~ 40 (no condensation)
Cable lead-in method	Based on specified code	Based on specified code	Based on specified code
No. of cable cores	3	3	6
Cable length	(Between Indicator unit and Detector head) 0.75 mm ² :200m or less 1.25 mm ² :600m or less 2.0 mm ² :1000m or less	(Between Indicator unit and Detector head) 0.75 mm ² :200m or less 1.25 mm ² :600m or less 2.0 mm ² : 1000m or less	(Between Indicator unit and Detector head) 0.75 mm ² :200m or less 1.25 mm ² :600m or less 2.0 mm ² :1000m or less
Painting color	Munsell 5YR6/13	Munsell 5YR6/13	Munsell 5YR6/13
Weight	1.2KGS	1.2KGS	6.2KGS

11. Consumable Parts and Spare Parts

Contact our dealer / agency when you need consumable parts and spare parts for NV-100H.

12. Warranty

New Cosmos Electric Company Limited, warrants its gas detection products against any defects in materials and workmanship under normal use and operating conditions, for a period of one year from the date of purchase.

All obligations and liabilities under this product warranty are limited to repairing or replacing at the manufacturer's option of the allegedly defective items returned to us, with carrier charges prepaid. All repairs and replacements are made subject to our factory inspection of the returned items.

No liability is accepted for the consequential damages or reinstallation labor. Defects as defined in the above shall not include decomposition by chemical reaction (including corrosion).

New Cosmos Electric Company Limited, shall not assume responsibility for contingent liability arising from alleged failure of any of its products and accessories.

13. Service Life

Service life of the equipment is seven years when installed and used as described in the installation instructions and instruction manual.

Replace with a new one after seven years for proper performance.

14. Glossary

Indicator / Alarm unit:	A unit that receives signals from the gas detector and indicates gas concentration and alarms.
Detector:	A unit that detects gas concentration and converts it to electric signals.
Backup power source device:	A device that supplies power to the gas detector, indicator / alarm unit in order to maintain its performance during a power failure.
Flow meter:	A meter to measure air flow in gas sampling pipe.
Gas collector:	A gas collecting probe that enhances gas collection efficiency and blocks water and dust.
Diffusion type:	A method to detect gas by utilizing convection and diffusion of gas.
Explosion proof construction:	A totally enclosed structure. When an explosive gas explodes in a container, the container can resist the pressure and prevent the ignition of explosive gases outside of it.
Preset alarm value:	A preset value for the alarm to go off when gas concentration reaches a certain value.
Gas to be detected:	Gas that is detected and indicated which sets off an alarm.
Detection range:	Range of gas's concentration that can be indicated and set off an alarm.
Alarm accuracy:	Difference between the preset alarm value and gas concentration when an alarm actually occurs or as the percentage of the difference compared to the preset alarm value.
Response time:	Time it takes from when the gas detector is exposed to a gas with a concentration higher (lower) than the preset alarm value until an alarm goes off.
Temperature range:	Range of temperature where the equipment can perform its functions.
Maintenance and inspections:	Work to guarantee that the equipment perform its required functions.
Calibration gas:	Gas used to calibrate scales of the equipment.
Peak hold:	A function to constantly update and hold the peak value of input signals.
Hazardous area:	An area in a plant or facility with a dangerous atmosphere where explosive gases may mix with air and explode or start a fire. An area where gas may be present.
Non hazardous area:	An area where electric equipment that has no potential to create a dangerous atmosphere.
Dangerous atmosphere:	Atmosphere within the explosive limit where explosive gas and air are mixed.
LEL: Lower Explosive Limit.	The lowest concentration of flammable gas that will explode when mixed with air and ignited.

(Quoted from gas detection terms and detector tube gas meter terms used by the Industrial Gas Detector Alarm Association.)

Manual Revision History

Edition No.	Date	Revisions
GAE-017	March 2004	0
GAE-017-01	December 2004	1

Additional copies of this Operation Manual are available.
Contact the following address for ordering information.

Distributor:**Manufacturer:**

New Cosmos Electric Co., Ltd.
2-5-4 Mitsuya-naka Yodogawa-ku
Osaka 532-0036, Japan
Phone 81-6-6309-1505
Fax 81-6-6309-1514
<http://www.new-cosmos.co.jp>

