

# SENSAIR<sup>™</sup> CMB

## Combustible Gas Transmitter

### User Manual

Document No. 360-0157-01 Rev D



## **SENSIDYNE<sup>®</sup>**

Sensidyne, LP • 1000 112<sup>th</sup> Circle N, Suite 100  
St. Petersburg, Florida 33716 USA  
800-451-9444 • +1 727-530-3602 • +1 727-539-0550 [fax]  
web: [www.sensidyne.com](http://www.sensidyne.com) • e-mail: [info@sensidyne.com](mailto:info@sensidyne.com)



## How to Use This Manual

This manual is a basic guide for using the SensAir Combustible Transmitter. It contains information on the transmitter, transmitter components, and the Normal Operation Display. It also shows how to mount and wire the transmitter, initial setup, zeroing, and span calibration. In addition, it covers commonly used operations regarding alarms and relays. For reference, the entire menu structure is outlined in [Appendix- Menu Map](#)

Because the SensAir Combustible Transmitter is menu driven, it is important to become familiar with how the magnetic switch controls are used to navigate through the menus, select specific menu items, and change the many different parameters available to the user. The Menu Map in the Appendix will help you toward this end.

# Table of Contents

How to Use This Manual .....	3
Packing List and Notices .....	6
WARNINGS.....	7
<b>1 INTRODUCTION .....</b>	<b>9</b>
<b>2 SENSAIR PART NUMBER SYSTEM.....</b>	<b>10</b>
<b>3 COMPONENTS.....</b>	<b>11</b>
3.1 Condulet Housing .....	11
3.2 Display .....	11
3.2.1 Electronics.....	11
3.3 The Sensor Assembly.....	12
<b>4 INSTALLATION .....</b>	<b>13</b>
4.1 Location .....	13
4.2 Transmitter Installation (Enclosure).....	13
4.3 Transmitter Location .....	14
4.3.1 Wiring .....	14
4.3.1.1 Transmitter Wiring Diagram.....	14
4.3.2 Allowable Line Length.....	15
4.3.3 Wiring Procedure .....	15
<b>5 OPERATION .....</b>	<b>16</b>
5.1 Output Current .....	16
5.2 Interferents.....	16
5.2.1 Flooding .....	16
5.2.2 Inhibition and Poisoning.....	17
<b>6 START UP PROCEDURE.....</b>	<b>18</b>
<b>7 CALIBRATION.....</b>	<b>19</b>
7.1 Equipment.....	19
7.2 Zeroing.....	19
7.3 Select Calibration Gas Concentration .....	19
7.4 Calibration Procedure .....	19
<b>8 MAINTENANCE .....</b>	<b>20</b>

- 8.1 Sensor Assembly Replacement .....20
- 8.2 4-20ma Adjustment Procedure .....21
- 9 APPENDIX- MENU MAP ..... 22**
- 10 APPENDIX- FAULT CODES..... 24**
- 11 APPENDIX- DIMENSIONAL DRAWINGS ..... 25**
  - 11.1 Standard, Horizontal Mounting .....25
  - 11.2 Vertical Mounting .....26
- 12 APPENDIX- CALIBRATION EQUIPMENT ..... 27**
  - Zero Calibration Gases .....27
  - Calibration Gases .....27
- 13 APPENDIX – ACCESSORIES AND SPARES..... 28**
- 14 APPENDIX- SPECIFICATIONS ..... 29**
- 15 APPENDIX- SELECTIVITY FACTORS..... 31**
- 16 APPENDIX- TROUBLESHOOTING GUIDE ..... 35**
- 17 RETURNED MATERIAL AUTHORIZATION..... 36**
- 18 APPROVAL RATINGS ..... 37**
- 19 CONTROL DRAWINGS..... 38**

## **Packing List and Notices**

### **You should have the following items:**

- SensAir Combustible Gas Transmitter unit
- Magnetic Screwdriver
- User Manual (this document)

Always check to make certain you have received all of the items listed above. If you have any questions or need assistance, contact your Sensidyne Representative, or call 800-451-9444 or +1 727-530-3602

### **PROPRIETARY NOTICE**

This manual was prepared by Sensidyne, LP exclusively for the owner of the SensAir Combustible Gas Transmitter. The material within this manual is the proprietary information of Sensidyne, LP and is to be used only to understand and operate the instrument. By receiving this document, the recipient agrees that neither this document nor the information disclosed within nor any part shall be reproduced or transferred, physically, electronically or in any form or used or disclosed to others for manufacturing or for any other purpose except as specifically authorized in writing by Sensidyne, LP.

### **COPYRIGHT NOTICE**

©2012, Sensidyne, LP All rights reserved. Information contained in this document is protected by copyright. No part of this document may be photocopied, reproduced, or translated to another program or system without prior written authorization from Sensidyne, LP

### **TRADEMARK NOTICE**

Sensidyne, the Sensidyne logo, SensAlert, the SensAlert & SensAir Combustible logos, T-O-D & Test-on-Demand are registered trademarks of Sensidyne, LP. The trademarks and service marks of Sensidyne, LP are protected through use and registration in the United States of America.

### **SOFTWARE LICENSE**

The software included with the SensAir Combustible Transmitter is the property of Sensidyne, LP and shall remain the property of Sensidyne, LP in perpetuity. The software is protected by U.S. and international copyright laws and is licensed for specific use with the SensAir Combustible Gas Transmitter. The user may not reverse-engineer, disassemble, decompile, or make any attempt to discover the source code of the software. The software may not be translated, copied, merged or modified in any way. The user may not sublicense, rent, or lease any portion of the software. The right to use the software terminates automatically if any part of this license is violated.

### **DISCLAIMER**

SENSIDYNE, LP ASSUMES NO RESPONSIBILITY WHATSOEVER, TO ANY PARTY WHOSOEVER, FOR ANY PROPERTY DAMAGE, PERSONAL INJURY, OR DEATH CAUSED BY OR RESULTING FROM, IN WHOLE, OR IN PART, THE IMPROPER USE, INSTALLATION, OR STORAGE OF THIS PRODUCT BY THE USER, PERSON, FIRM, ENTITY, CORPORATION OR PARTY NOT ADHERING TO THE INSTRUCTIONS AND WARNINGS OR NOT ADHERING TO ALL FEDERAL, STATE, AND LOCAL ENVIRONMENTAL AND OCCUPATIONAL HEALTH AND SAFETY LAWS AND REGULATIONS. THE SELLER SHALL NOT BE LIABLE FOR DIRECT, INDIRECT, CONSEQUENTIAL, INCIDENTAL OR OTHER DAMAGES RESULTING FROM THE SALE AND USE OF ANY GOODS AND SELLER'S LIABILITY HEREUNDER SHALL BE LIMITED TO REPAIR OR REPLACEMENT OF ANY GOODS FOUND DEFECTIVE. THIS WARRANTY IS IN LIEU OF ALL OTHER WARRANTIES, EXPRESSED OR IMPLIED, INCLUDING BUT NOT LIMITED TO THE IMPLIED WARRANTIES OF MERCHANTABILITY AND FITNESS FOR USE OR FOR A PARTICULAR PURPOSE WHICH ARE EXPRESSLY DISCLAIMED.

**WARNINGS****READ AND UNDERSTAND ALL WARNINGS AND INSTRUCTIONS BEFORE USE**

**Failure to read, understand, and comply with ALL accompanying literature, instructions, product labels, and warnings could result in property damage, severe personal injury, or death.**

Product is tested and calibrated at the factory prior to shipment. However, this product must be calibrated prior to initial use and at regular intervals in accordance with this User Manual to ensure proper operation.

**Failure to calibrate and operate this product in accordance with this User Manual may result in the malfunction of the product.**

Read and understand ALL applicable federal, state, and local environmental health and safety laws and regulations, including OSHA. Ensure complete compliance with ALL applicable laws and regulations before and during use of this product.

The user/installer must understand the Hazardous Area Protection Concepts and Area Classifications applicable to their operation.

Metal conduit with a conduit seal within 18" of the conduit must be used to ensure that the installation is explosion-proof,

UNDER NO CIRCUMSTANCES should this product be used except by qualified, trained, technically competent personnel and not until the warnings, User Manual, labels, and other literature accompanying this product have been read and understood.

Failure to read and understand the User Manual may result in preventable severe personal injury or death.

ALWAYS wash your hands thoroughly after handling, calibrating, or servicing this product.

ALWAYS wear eye protection (such as safety goggles), face shield, chemical resistant gloves and chemical resistant clothing when handling chemicals, or calibration sources.

DO NOT get chemicals, gases, fumes, or vapors in your eyes or on your skin, as they may cause severe burns to skin and eyes. If chemicals, gases, fumes, or vapors get in your eyes or on your skin, wash the affected area with copious amounts of water and call a physician immediately.

ALWAYS avoid any contact of acids with your skin or eyes. Seek immediate medical attention for any contact with acids.

ALWAYS calibrate in a well ventilated area. Adequate precautions should be taken to prevent the buildup of ANY calibration sources or vapors. Avoid breathing ANY calibration fumes or vapors as they may be hazardous to your health.

ALWAYS dispose of chemicals and calibration sources in compliance with ALL applicable safety laws, regulations, and guidelines for proper disposal. Failure to do so may result in environmental damage, property damage, personal injury or death.

ALWAYS close ALL containers of chemicals used with this product after use.

ALWAYS ensure that any compressed calibration substance sources are empty prior to disposal, should they be used.

ALWAYS use clean, dry, inert materials to contain and transfer substances used for calibration.

DO NOT remove, cover, or alter any label or tag on this product, its accessories, or related products.

DO NOT operate this product should it malfunction or require repair. Operation of a malfunctioning product, or a product requiring repair may result in serious personal injury or death.

DO NOT attempt to repair or modify instrument, except as specified in the Operation & Service Manual. If repair is needed, contact the Sensidyne Service Dept. to arrange for a Returned Material Authorization (RMA) [Returned Material Authorization](#)

Users should refer to MSDS and suppliers' instructions for proper handling and safety instructions for any chemicals used with this equipment.

**WARNINGS**  
**READ AND UNDERSTAND ALL WARNINGS BEFORE USE**

Use ONLY genuine SENSIDYNE® replacement parts when performing any maintenance procedures described in this manual. Failure to do so may seriously impair instrument performance and affect the Hazardous Area Certification. Repair or alteration of the product beyond the scope of these maintenance instructions, or by anyone other than an authorized SENSIDYNE® service technician, could cause the product to fail to perform as designed and persons who rely on this product for their safety could sustain severe personal injury or death.

The SensAir Combustible Gas Transmitter is an ambient air monitoring device. Restricting the access of ambient air to the sensor may result in less than optimal monitoring performance.

Caution: For safety reasons this equipment must be operated and serviced by qualified personnel only. Read and understand instruction manual completely before operating or servicing.

Attention: Pour des raisons de securite, cet equipement doit etre utilise, entretenu et repare uniquement par un personnel qualifie. Etudier le manual d'instructions en entier avant d'utiliser, d'entretenir ou de reparer l'equipement.

Prolonged exposure to excessively high concentrations of flammable gas may cause the sensor to produce erroneous readings.

Always make use of a rainshield to protect against variations caused by environmental conditions.

Perform tests only within the specified operating ranges.

Sudden changes in pressure may cause temporary fluctuations in the sensor reading.

For Class 1 Division installations: Do not install in atmospheres containing keytones, alcohols, esters and acidic atmospheres.

**Important Calibration Considerations:**

Unit calibration must be done at altitude.

Verify concentration of calibration gas before making calibration adjustments.

Concentration can be altered by:

Deterioration of the concentration of compressed calibration gas sources during storage.

Interaction of the calibration gas with materials used to contain and transfer the gas, as for example, absorption onto and permeation through certain plastics.

Interaction of the calibration gas with materials and/or ambient contaminants, as for example, absorption into water.

If further translation is required, please contact the Sensidyne EU Authorized Representative (see Back Cover for contact information).



# 1 INTRODUCTION

---

This manual provides specific information concerning the installation, operation, calibration, and maintenance of the SensAir Combustible Gas Transmitter.

**IMPORTANT:** Owners of the Combustible Gas Transmitter must read this manual in its entirety in order to ensure proper operation of the transmitter.

The SensAir Combustible Gas Transmitter is an explosion-proof, single-point device capable of detecting the presence of various substances, which are either flammable gases or produce flammable vapors. The transmitter detects each substance below its LEL (Lower Explosive Limit) before the concentration is great enough to create a potentially explosive atmosphere.

The standard transmitter consists of a display board and a power supply board housed in an explosion proof conduit, and a stainless steel catalytic bead sensor specifically designed to detect combustible substances.

A complete monitoring system consists of the transmitter and a separate read-out device & power supply capable of monitoring a 4-20 mA output and supplying 12-30 Vdc power.

Product specifications are located in Appendix B.

Different versions of the transmitter are available ([see Part Number Table](#)). The selection of the version best suited to an application depends upon the application requirement.

A stainless steel sensor is for improved corrosion resistance in harsh ambient environments.

The sensor assembly is poison resistant and suitable for use where substances can inhibit and poison the sensor are known to be present in low concentrations. The substances include:

- Silicon-containing compounds, such as silicone oils and greases (e.g., HMDS)
- Phosphorus-containing compounds, such as pesticides.
- Sulfur-containing compounds, such as carbon disulfide and hydrogen sulfide
- Halogen-containing compounds, such as fluoro- and chloro-carbons
- Lead-containing compounds, such as anti-knock petroleum additives
- Metal-containing hydride gases.

## 2 SensAir Part Number System

### SensAir Combustible WITH DISPLAY

8 2 0 - 0    -

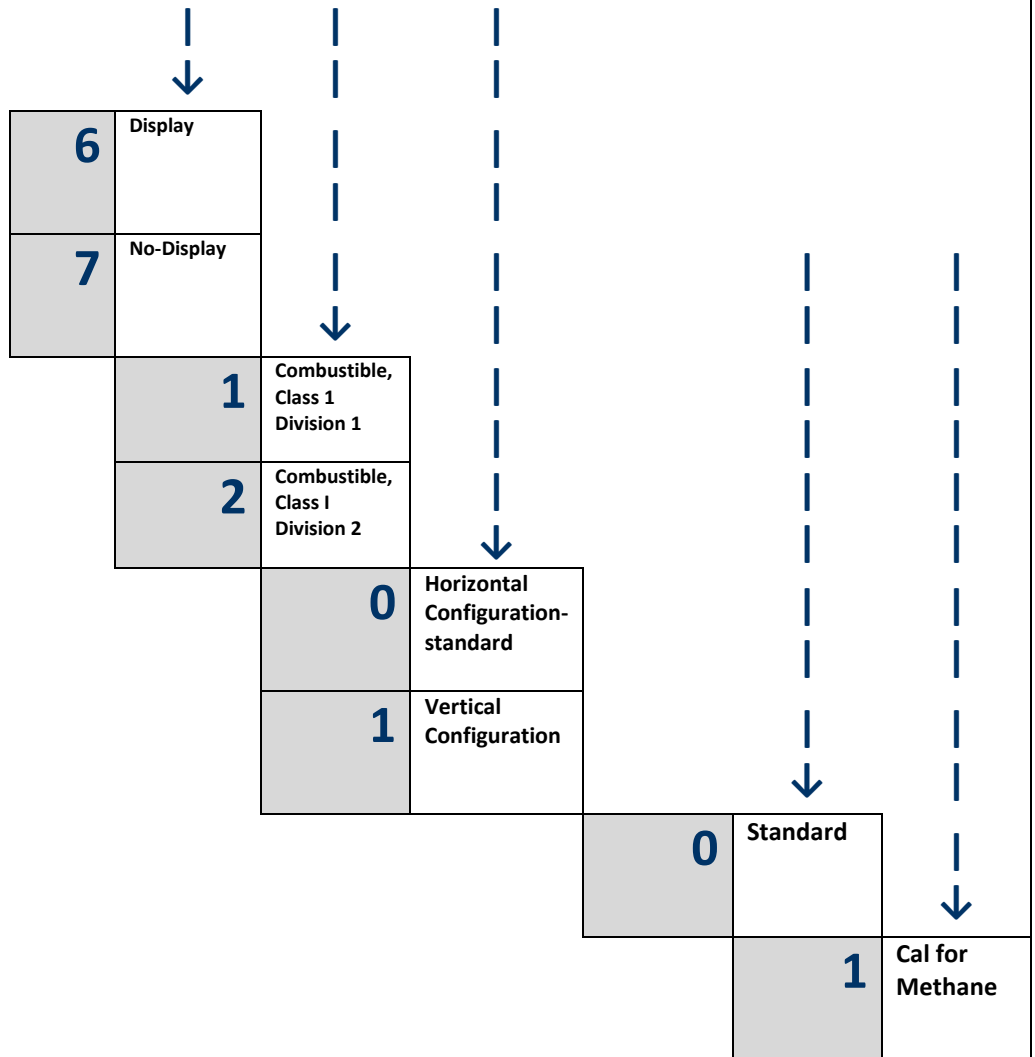

## 3 Components

---

### 3.1 Condulet Housing

The condulet housing is made of cast aluminum, which provides an explosion-proof weather-resistant barrier between the electronics module and the ambient environment. The condulet is explosion-proof to protect the electronics from damage due to an external explosion and to prevent any electrical malfunction of the electronics module from triggering an external explosion. The housing is available with a window for the display of the transmitter.

An o-ring on the condulet seated between the condulet cover and the base provides water-tight protection for the internal electronic components. It allows the transmitter to be used outdoors during inclement weather conditions.

### 3.2 Display

The transmitter with display has Program and Up and Down selector magnetic switches. These are controlled via the magnetic screwdriver provided with the unit. Information on operating the various controls is located in the [Appendix Menu Map](#).

The display shows the following:

(1) **Gas Concentration**

The gas concentration is displayed in large characters, units of measure are %LEL.

(2) **PROGRAM Control (Switch)**

The Program switch is used to enter the programming menu. The switch is also used to select/save a menu item.

(3) **▲ and ▼**

The ▲ and ▼ control arrows are used to scroll up or down a list of items. These controls are also used to increase or decrease a value (such as sensor voltage or k-factor).

Holding the wand near the control (switch) causes the displayed value to either increase or decrease automatically.

(4) **LEDs**

The transmitter display has LEDs that light up when there is a fault condition occurring or during menu selection.

Also, when the magnetic wand is brought close to a magnetic switch the LED associated with that switch lights up, confirming that contact has been made between the wand and the switch.

#### 3.2.1 Electronics

The electronics inside the condulet consist of a display board and a power supply board. They are housed within the explosion-proof condulet, and converts the sensor response into a 4-20 mA current, linearly proportional to the concentration of the combustible gas present at the sensor.

### 3.3 The Sensor Assembly

**CAUTION: DO NOT attempt to install the sensor assembly into any transmitter other than the designated SensAir Combustible Gas Transmitter.**

The sensor assembly consists of a catalytic bead in a stainless steel housing. Stainless steel is recommended for improved corrosion resistance in harsh ambient environments.

The catalytic device detects a combustible substance before the concentration becomes potentially explosive. Ambient gas or vapor diffuses to the sensor where the catalyst causes it to oxidize even though the concentration is less than 100 %LEL. Heat produced by this reaction at the sensor is proportional to the concentration of the combustible substance. The heat produced is converted into an electrical signal which is monitored by the electronics. The sensor is capable of detecting combustible substances in the range 0-100 %LEL.

**WARNING: The sensor CANNOT be used to detect toxic hazards.**

#### Example

Acetaldehyde has a 100 %LEL of 4 %v (by volume) which is equal to 40,000 ppm. Thus 100 %LEL is equivalent to 4 %v (40,000 ppm), and 1 %LEL is equivalent to 0.04 %v (400 ppm). Acetaldehyde is also toxic, having a Threshold Limit Value (TLV) of 100 ppm. However, since the minimum detectable concentration, 1 %LEL, is greater than the TLV, the sensor cannot be used to monitor for toxic hazardousness.

The sensor can be inhibited and damaged if it is "flooded" by exposure to concentrations greater than 100 %LEL. Exposure to concentrations above 100%LEL causes an over-range indication followed by indication below 100 %LEL, due to loss of sensitivity even though a potentially explosive concentration of the combustible gas or vapor still exists. Therefore, should an over-range condition ever exist, always investigate carefully and thoroughly before entering the affected area.

## 4 Installation

---

### 4.1 Location

The Combustible Gas Transmitter is a local area detector. It is imperative that the transmitter be located in an area where the greatest concentration of the target gas will be present in the shortest period of time after the occurrence of a leak or other increase in the concentration of the target gas in the atmosphere. Expert consultation may be necessary to determine the most strategic location for optimum monitoring. In all circumstances, the plant safety officer or other appropriate personnel should be consulted before installation.

Site determination, at a minimum, must consider the following factors:

- most probable location of a leak
- physical properties of the target gas
- air convection in the area due to ventilation or ambient conditions
- operational environment
- presence of interferent gases

Ultimately, monitoring efficiency, and the degree of protection it affords, depends upon how carefully this survey is made.

### 4.2 Transmitter Installation (Enclosure)

Refer to all local electrical codes to ensure compliance for proper mounting.

The transmitter mounts to a wiring conduit via (19 mm) 3/4" female NPT at the conduit. Metal conduit (with a conduit seal within 18" of the conduit) must be used to ensure that the installation is explosion-proof. To achieve a measure of RFI/EMI immunity, the enclosure and conduit must be grounded and shielded cable must be used.

The transmitter should be mounted with the sensor facing down to prevent moisture and debris from collecting on the sensor itself.

- 1) Get confirmation from the safety officer that the area is free of hazardous atmospheres.
- 2) Unscrew and remove the conduit cover.
- 3) Confirm that the input and output wires are without power and thread (thread) them through the opening of the conduit.
- 4) Hold the wires out of the way and screw the conduit firmly into the conduit.
- 5) Cap the wires and replace the conduit cover if you are not going to wire the transmitter at this time.

**NOTE**

Five full threads of engagement are required to maintain explosion-proof rating.

## 4.3 Transmitter Location

### 4.3.1 Wiring

Refer to all local electrical codes to ensure proper wiring compliance. The use of shielded wire is recommended.

**NOTE**

The power supply must have a power source return isolated from earth ground. Shielded cable is recommended with shield terminated to earth ground to ensure a measure of RFI/EMI immunity. If the metal conduit to which the transmitter is mounted is not earth grounded, the conduit must be earth grounded via the green wire.

The following sections provide specific information necessary to wire the transmitter to a power supply. A wiring diagram is provided to aid in wiring the transmitter to a power supply.

Three (3) wires are required to connect the transmitter to a Sensidyne controller, or a customer supplied 12-30 Vdc power supply and read-out device. See Figure 4.3.1 for wiring.

#### 4.3.1.1 Transmitter Wiring Diagram

**NOTE**

Installation and wiring must be in accordance with National Electrical Code. Temperature rating of cable wire insulation must be specified to be above 75 C (167 F). If cable runs through temperatures which exceed 75 C, it should be specified for that environment.

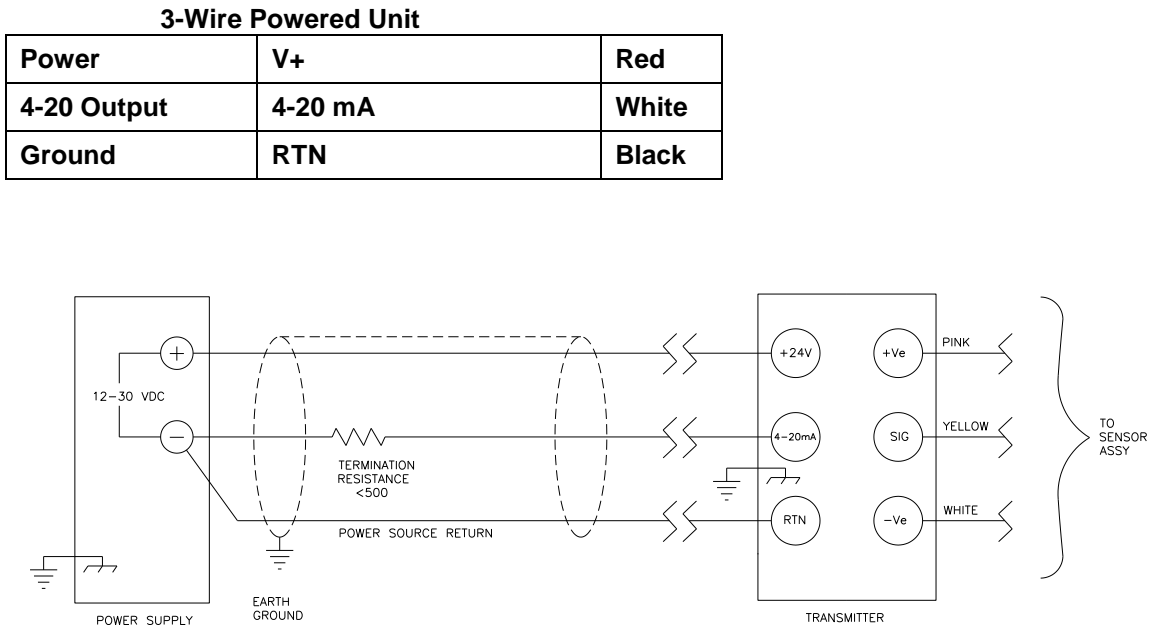

**FIGURE 4.3.1  
TRANSMITTER WIRING**

### 4.3.2 Allowable Line Length

The maximum distance between the power supply and the transmitter is known as the allowable line length. It is a function of the power supply voltage, loop resistance, and termination resistance. This in turn determines allowable loop resistance and wire size.

The allowable line lengths for various wire sizes as well as the allowable loop resistance for various power supply voltages. The allowable voltage range for the power supply is 12-30 Vdc.

### 4.3.3 Wiring Procedure

The transmitter terminals will not accept wire gauges larger than 14 AWG. In all cases, the connections must be clean, tight and protected from the weather. They must meet all required electrical codes.

Wire the transmitter as follows:

- 1) Get confirmation from the safety officer, or appropriate personnel, that the area is safe.
- 2) Verify that the conduit and the transmitter are securely connected together.
- 3) Verify that the input and output wires are (without power).
- 4) Unscrew and remove the conduit cover.
- 5) Verify that the total resistance of the wiring does not exceed the allowable loop resistance
- 6) Attach and secure the power source return (negative lead) wire to the "RTN" Terminal (3) on the J1 connector.
- 7) Attach and secure the 4-20 mA output wire to the "4–20 mA" Terminal (2) on the J1 connector.
- 8) Attach and secure the positive lead wire to the "V+" Terminal (1) on the J1 connector.
- 9) Replace the conduit cover if not proceeding with start-up at this time.
- 10) Before applying power to the transmitter, verify that all connections are correct.
- 11) Go to Start-Up Section when you are ready to perform the start-up procedure.

## 5 Operation

---

NOTE: The transmitter must be calibrated after initial installation and before normal operation is possible. (See Calibration Section)

Monthly calibration is recommended to ensure proper operation. NOTE: Catalytic Bead sensors do not “fail safe” therefore, monthly calibration is recommended.

Under normal operating conditions, the transmitter responds to the presence of combustible gas by producing a 4-20 mA current that is linearly proportional to the concentration of combustible gas present at the sensor.

### 5.1 Output Current

When calibrated, the relationship between the output current of the transmitter (in mA) and the concentration of the target gas is linear. Concentration is shown as a Percentage of Full Scale. Because the SensAir Combustible Gas Transmitter measures 0–100%LEL, 100 %LEL = 100% of Full Scale.

The transmitter is designed to respond similarly to most combustible substances at their respective Lower Explosive Limit (LEL) concentrations, despite the fact that these combustible substances may differ greatly in their concentrations as measured in %v (percent by volume) or ppm (parts per million).

For example, Methane becomes potentially explosive (100 %LEL) at a 5 %v (by volume) concentration, while n-Octane becomes potentially explosive (100%LEL) at a 1 %v concentration. Despite the fact that the percent by volume concentrations of methane and n-octane are different, the response of the transmitter to equal %LEL concentrations of methane and n-octane is very similar.

[See Appendix](#) for LEL characteristics and approximate selectivity factors for many common combustible substances

### 5.2 Interferents

#### 5.2.1 Flooding

Flooding occurs when there is exposure to flammable gas or vapor concentrations greater than 100 %LEL (regardless of the actual % by volume). The transmitter is not suitable for detection of combustible substances at any concentration greater than 100 %LEL. The catalytic device within the sensor assembly can be inhibited and damaged by exposure to such a large concentration. In the typical flooded response the appearance of an output current greater than 20 mA occurs (an over- range condition), followed closely by a decrease in the output current to values less than 20 mA. However, the following decrease in output current is NOT necessarily due to dissipation of the combustible substance.

Following a flooded response – when the area is again safe – the transmitter must be re-calibrated in order to ensure that the sensor assembly has not been damaged. If calibration is not successful the catalytic device has been damaged and the sensor assembly must be replaced.

**WARNING:** Should an overrange condition occur, followed very closely by an apparent decrease in the concentration level, investigate the area. Consult the Safety Officer and CAREFULLY and THOROUGHLY investigate before entering. A potentially explosive concentration of the combustible substance may still exist.



## 5.2.2 Inhibition and Poisoning

Inhibition and Poisoning occur when the combustible by-products from some compounds are deposited onto the catalytic device within the sensor assembly. These depositions will deactivate the sensor. The degree of deactivation may be either partial or complete and may be either reversible or irreversible depending upon the concentration and the duration of exposure to the interfering compound.

The sensor assembly should never be exposed to any of the following substances known to inhibit and poison the catalytic device:

- Silicon-containing compounds, such as silicone oils and greases
- Phosphorous-containing compounds, such as pesticides
- Sulfur-containing compounds, such as carbon disulfide and hydrogen sulfide
- Halogen-containing compounds, such as fluoro- carbons and chlorocarbons
- Lead-containing compounds, such as anti-knock petroleum additives
- Metal-containing hydrides.
- Hydrocarbon compounds that polymerize and carburize on heating, such as styrene.

**WARNING:** Following exposure to a poisonous substance, the transmitter must be re-calibrated in order to assure that the sensor assembly has not been damaged. If calibration is not successful the catalytic device has been damaged and the sensor assembly must be replaced.

## 6 Start Up Procedure

---

It is necessary to perform the following start up procedure upon initial installation. Performance of the startup procedure is not ordinarily required at the time of routine periodic calibration. However, the startup procedure should be performed when any of the following occurs:

- loss of power for an extended period time
- upon sensor assembly replacement
- following a flooded response

**WARNING: The safety officer must ensure that the area is safe before the conduit may be opened.**

- 1) Unscrew and remove the conduit cover.
- 2) Make certain the transmitter has been wired properly.
- 3) Apply power to the transmitter. Observe that the Display has proper indications. If the Display does not have proper indication go to [Appendix Troubleshooting Guide](#) to determine the cause of the problem.

CAUTION: Do not continue with the start-up procedure until this problem has been corrected.

- 4) Allow the transmitter to warm up for at least 15 minutes.
- 5) Replace the conduit cover. Allow the unit to stabilize for at least 1 hour before calibrating the transmitter

Your Sensidyne gas detector is tested and calibrated at the factory prior to shipment. However, this product must be calibrated prior to initial use and at regular intervals in accordance with this User Manual to ensure proper operation.

**WARNING: Failure to calibrate and operate this product in accordance with this User Manual may result in the malfunction of the product.**

After installation and stabilization of the gas detector, qualified personnel must verify calibration by applying zero and span gases. **This procedure should be performed at initial commissioning and then repeated 30 and 60 days thereafter, with deviations in zero and span recorded. The gas detector should then be calibrated at intervals dependent on the application, but no less often than once every 90 days.**  
**Sensors must always be calibrated upon installation and after a gas alarm.**

Failure to maintain this schedule could result in impaired system performance and/or erroneous readings.

**CAUTION:** Catalytic Bead sensors do not “fail safe”.

### **NOTE**

If calibration is being performed prior to initial use or after sensor replacement, the transmitter must be allowed to stabilize with power applied for 1 hour before attempting the calibration procedure.

For further information on industry standards for sensor calibration, please refer to *Recommended Practice for the Installation, Operation, and Maintenance of Combustible Gas Detection Instruments* (ANSI/ISA TR12.13.02-2003) published by the ISA.

# 7 Calibration

---

**NOTE:** The calibration procedure should be performed at ambient conditions including altitude, with special attention paid to the humidity and temperature requirements of the transmitter. Zeroing must be performed prior to Calibration.

## 7.1 Equipment

### Calibration Gas

Sensidyne offers a full line of equipment for properly calibrating the SensAir Combustible Gas Transmitter. Calibration equipment available for the Combustible Gas Transmitter is described below. Refer to Appendix Accessories and Spares for ordering information, and for a complete listing of available calibration equipment and accessories, see appendix: Calibration Equipment. Each calibration gas cylinder is shipped with an MSDS sheet (a NIST traceable calibration certificate also is available upon request).

### Regulator

0.5LPM regulator is recommended.

### Calibration Cup

## 7.2 Zeroing

- Apply Zero Gas.  
*Using the magnetic wand:*
- Hold “Program” for 2 seconds
- ZrO will appear
- Hold “Program” for 2 seconds to select
- “Up” arrow LED will light. Zeroing of transmitter taking place
- After 60 seconds, “Up” arrow LED will go out signifying Zeroing is complete.

## 7.3 Select Calibration Gas Concentration

Using the magnetic wand:

- Hold “Program” for 2 seconds
- ZrO will appear
- Hold “Down” until GAS appears
- Hold “Program” for 2 seconds to select
- Saved Calibration Gas Concentration will appear
- Use “Up” and “Down” to adjust the Calibration Gas Concentration if needed
- Hold “Program” for 2 seconds to save new gas concentration

## 7.4 Calibration Procedure

Using the magnetic wand:

- Hold “Program” for 2 seconds.
- ZrO will appear
- Hold “Down” for 1 second
- CAL will appear
- Hold “Program” for 2 seconds to select
- Down arrow LED will light (calibrating transmitter). To Escape calibration mode hold “UP” for 15 seconds
- Apply gas
- After 60 seconds of stable gas, “Down” arrow LED will go out and calibration is complete.
- Pass or Failure code will appear.
- Remove gas.
- Normal display will return after test gas dissipates.

## 8 Maintenance

**NOTE:** See Section 7 for calibration recommendations.

The Sensidyne SensAir Combustible Gas Transmitter does not require any periodic maintenance unless a malfunction occurs. In the event of a malfunction, refer to Appendix Troubleshooting Guide. Use the Troubleshooting Guide to determine the cause of and remedy for common problems which may occur in the field.

This section describes certain simple maintenance procedures that may be performed in the field.

- Sensor assembly replacement. The disposable sensor assembly should be replaced if it is damaged or when it no longer performs properly.
- 4-20mA current loop adjustment.

### 8.1 Sensor Assembly Replacement

**CAUTION:** The transmitter is certified explosion-proof and is intended for use in areas which may contain potentially explosive substances. The safety officer must ensure that the area is safe before the conduit is opened.

- Remove power from the transmitter.
- Unscrew and remove the conduit cover.
- Disconnect the 3 colored wires from the sensor.
- Remove the rainshield if one is attached. Unscrew and remove the old sensor assembly from the lower opening of the conduit.
- Discard the old assembly.
- Thread the three colored wires from the new sensor assembly through the lower opening of the conduit.
- Apply sealant to the threads of the new sensor assembly housing to ensure a watertight seal and prevent seizing. Silicone based sealant must never be used on or near these sensors. Conductive pipe dope is recommended.
- Screw the new sensor assembly firmly into place.
- Connect and secure the white wire to “-Ve” Terminal (1) on the Sensor (J2) terminal strip.
- Connect and secure the yellow wire to the “SIG” Terminal (2) on the Sensor (J2) terminal strip.
- Connect and secure the pink wire to “+Ve” Terminal (3) on the Sensor (J2) terminal strip.
- Make certain all wiring is secure.
- Connect voltmeter to TP3 and TP4. Apply power to the transmitter.

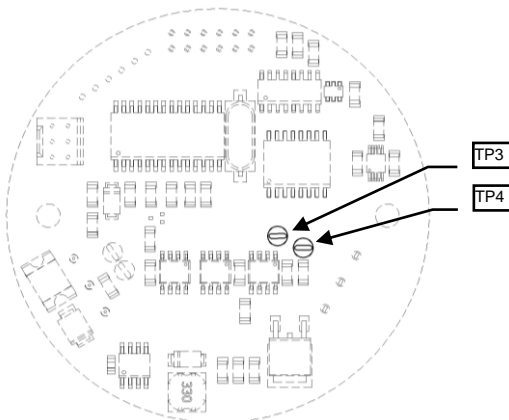

- Through the Adj menu adjust the sensor voltage to 2.000 volts DC.
- Replace and secure the conduit cover. Make certain the conduit o-ring is properly seated when tightening the conduit. 5 full threads are required to meet the XP rating. Allow the transmitter to warm up for at least 15 minutes.

## 8.2 4-20ma Adjustment Procedure

CAUTION: The transmitter is certified explosion-proof and is intended for use in areas which may contain potentially explosive substances. The safety officer must ensure that the area is safe before the conduit is opened.

- Unscrew and remove the conduit cover.
- Connect voltmeter to TP1 and TP2. Apply power to the transmitter.
- Through the Adjust 4-20mA current loop 4mA setpoint menu (see Section 9: step 1.7); adjust the voltage at test points to the following:
  - 4ma Set Point: Test Point Voltage = 40.0 mV
- Through the Adjust 4-20mA current loop 20mA setpoint menu (see Section 9: step 1.8); adjust the voltage at test points to the following:
  - 20ma Set Point: Test Point Voltage = 200.0 mV
- Replace and secure the conduit cover. Make certain the conduit o-ring is properly seated when tightening the conduit. 5 full threads are required to meet the XP rating.

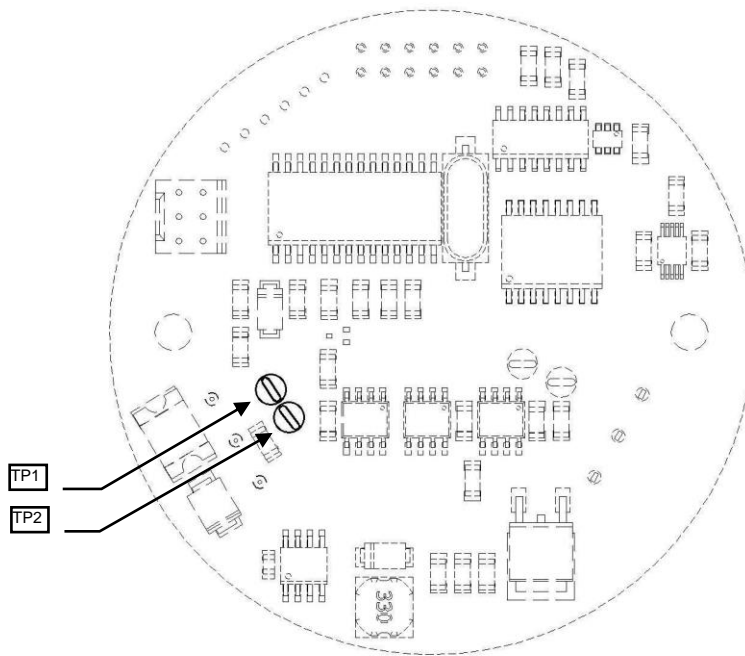

## 9 Appendix- Menu Map

---

The setup and operation of the SensAir Combustible is controlled by parameters and procedures that are accessed through the menu structure.

### Menu Map

#### 1. Transmitter Modes

##### 1.1. Zeroing

- 1.1.1. Hold "Program" for 2 seconds.
- 1.1.2. ZrO will appear.
- 1.1.3. Hold "Program" for 2 seconds to select.
- 1.1.4. Up arrow LED will light (zeroing transmitter).
- 1.1.5. After 60 seconds Up arrow LED will go out (zeroing completed).

##### 1.2. Calibration

- 1.2.1. Hold "Program" for 2 seconds.
- 1.2.2. ZrO will appear.
- 1.2.3. Hold "Down" for 1 second.
- 1.2.4. CAL will appear.
- 1.2.5. Hold "Program" for 2 seconds to select.
- 1.2.6. Down arrow LED will light (calibrating transmitter), if "Up" held for 15 seconds escape calibration mode.
- 1.2.7. Apply gas, if "Up" held for 15 seconds escape calibration mode.
- 1.2.8. After 60 seconds of stable gas Down arrow LED will go out (calibration completed).
- 1.2.9. Pass or Failure Code will appear.
- 1.2.10. Remove gas.
- 1.2.11. Normal display will return after test gas dissipates.

##### 1.3. Calibration Gas Concentration

- 1.3.1. Hold "Program" for 2 seconds.
- 1.3.2. ZrO will appear.
- 1.3.3. Continue to hold "Down" until GAS appears.
- 1.3.4. Hold "Program" for 2 seconds to select.
- 1.3.5. Present calibration gas concentration will appear and High Alarm LED will light.
- 1.3.6. Using the Up / Down arrows the gas concentration will change once a second.
- 1.3.7. Hold "Program" for 2 seconds to save gas concentration, or no user action for 20 seconds and the gas concentration will revert to the previous value.
- 1.3.8. Unit will return to the normal screen.

##### 1.4. Adjust K Factor

- 1.4.1. Hold "Program" for 2 seconds.
- 1.4.2. ZrO will appear.
- 1.4.3. Continue to hold "Down" until FcT appears.
- 1.4.4. Hold "Program" for 2 seconds to select.
- 1.4.5. Present K Factor will appear and High Alarm LED will light.
- 1.4.6. Using the Up / Down arrows the gas concentration will change once a second. The limits are 3.0 and 0.5.

- 1.4.7. Hold "Program" for 2 seconds to save the K Factor, or no user action for 20 seconds and the K Factor will revert to the previous value.
- 1.4.8. Unit will return to the normal screen.
- 1.5. Hold Current Loop
  - 1.5.1. Hold "Program" for 2 seconds.
  - 1.5.2. ZrO will appear.
  - 1.5.3. Continue to hold "Down until HOd appears.
  - 1.5.4. Hold "Program" for 2 seconds to select.
- 1.6. Sensor Voltage Adjust
  - 1.6.1. The sensor voltage must be adjusted anytime the sensor is replaced in the main transmitter. The voltage at the sensor must be maintained at 2.000 +/- 0.005 Volts DC.
  - 1.6.2. If the sensor voltage is adjusted the sensor must be re-zeroed and calibrated.
  - 1.6.3. Hold "Program" for 2 seconds.
  - 1.6.4. ZrO will appear.
  - 1.6.5. Continue to hold "Down" until Adj appears.
  - 1.6.6. Hold "Program" for 2 seconds to select.
  - 1.6.7. Three dashes will appear and High Alarm LED will light.
  - 1.6.8. Using the Up / Down arrows the sensor voltage will change every 0.2 seconds.
  - 1.6.9. Hold "Program" for 2 seconds to save the sensor voltage, or no user action for 20 seconds and the sensor voltage will revert to the previous value.
  - 1.6.10. Unit will return to the normal screen.
- 1.7. Adjust 4 – 20 mA current loop 4 mA setpoint
  - 1.7.1. Hold "Program" for 2 seconds.
  - 1.7.2. ZrO will appear.
  - 1.7.3. Continue to hold "Down" until A 4 appears.
  - 1.7.4. Hold "Program" for 2 seconds to select.
  - 1.7.5. Three dashes will appear and High Alarm LED will light.
  - 1.7.6. Using the Up / Down arrows the 4 mA setpoint will change every 0.2 seconds.
  - 1.7.7. Hold "Program" for 2 seconds to save the setpoint, or no user action for 20 seconds and the setpoint will revert to the previous value.
  - 1.7.8. Unit will return to the normal screen.
- 1.8. Adjust 4 – 20 mA current loop 20 mA setpoint
  - 1.8.1. Hold "Program" for 2 seconds.
  - 1.8.2. ZrO will appear.
  - 1.8.3. Continue to hold "Down" until A20 appears.
  - 1.8.4. Hold "Program" for 2 seconds to select.
  - 1.8.5. Three dashes will appear and High Alarm LED will light.
  - 1.8.6. Using the Up / Down arrows the 20 mA setpoint will change every 0.2 seconds.
  - 1.8.7. Hold "Program" for 2 seconds to save the setpoint, or no user action for 20 seconds and the setpoint will revert to the previous value.

## **10 Appendix- Fault Codes**

---

F00 – Not Assigned

F01 – Sensor Failed

F02 – Cal Mode Calibration Fail, outside gain range

F03 – Cal Mode Gas not present after 5 minutes, User aborted calibration

F04 – Cal Mode Gas not stable after 5 minutes, User aborted calibration



# 11 Appendix- Dimensional Drawings

## 11.1 Standard, Horizontal Mounting

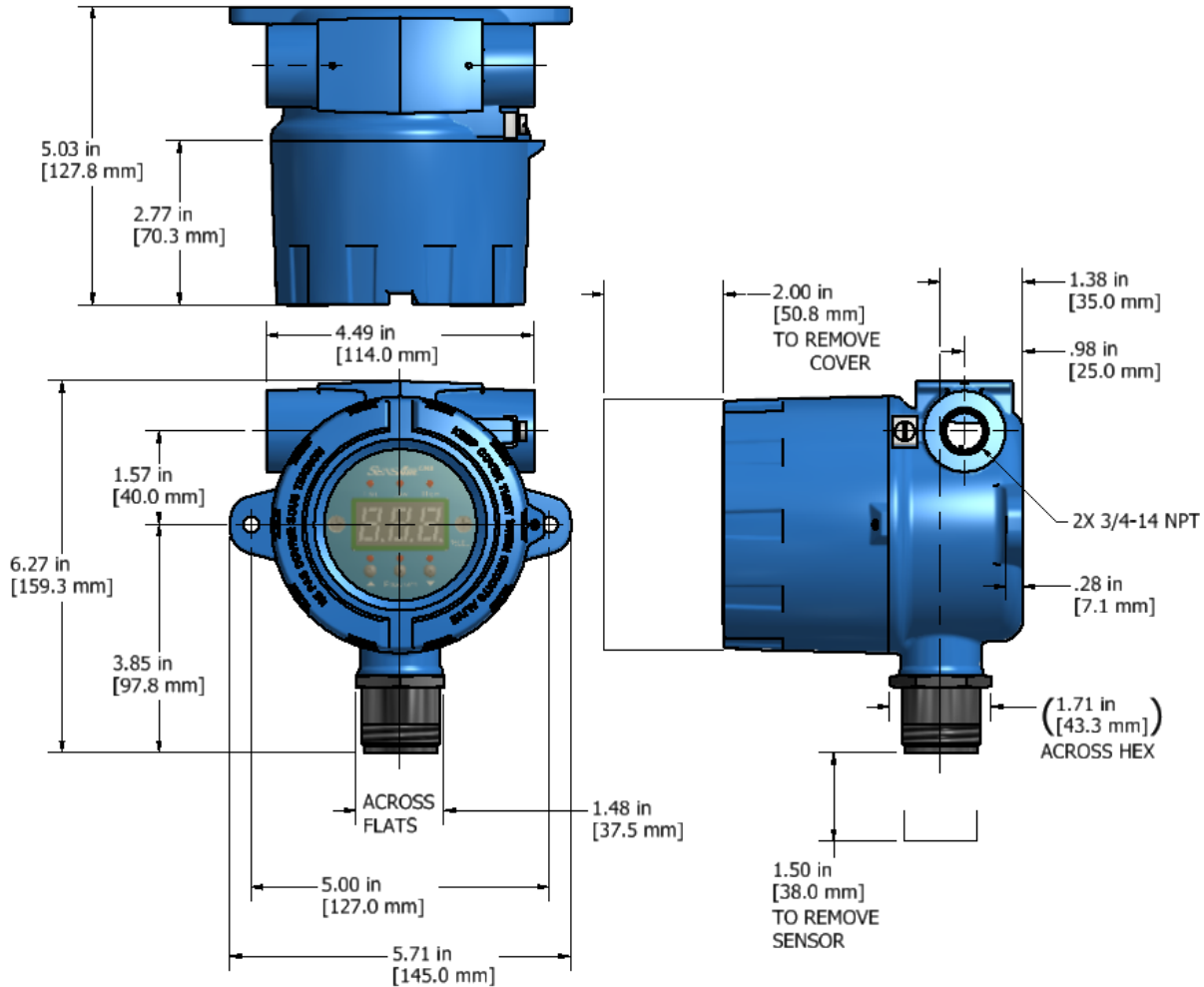

## 11.2 Vertical Mounting

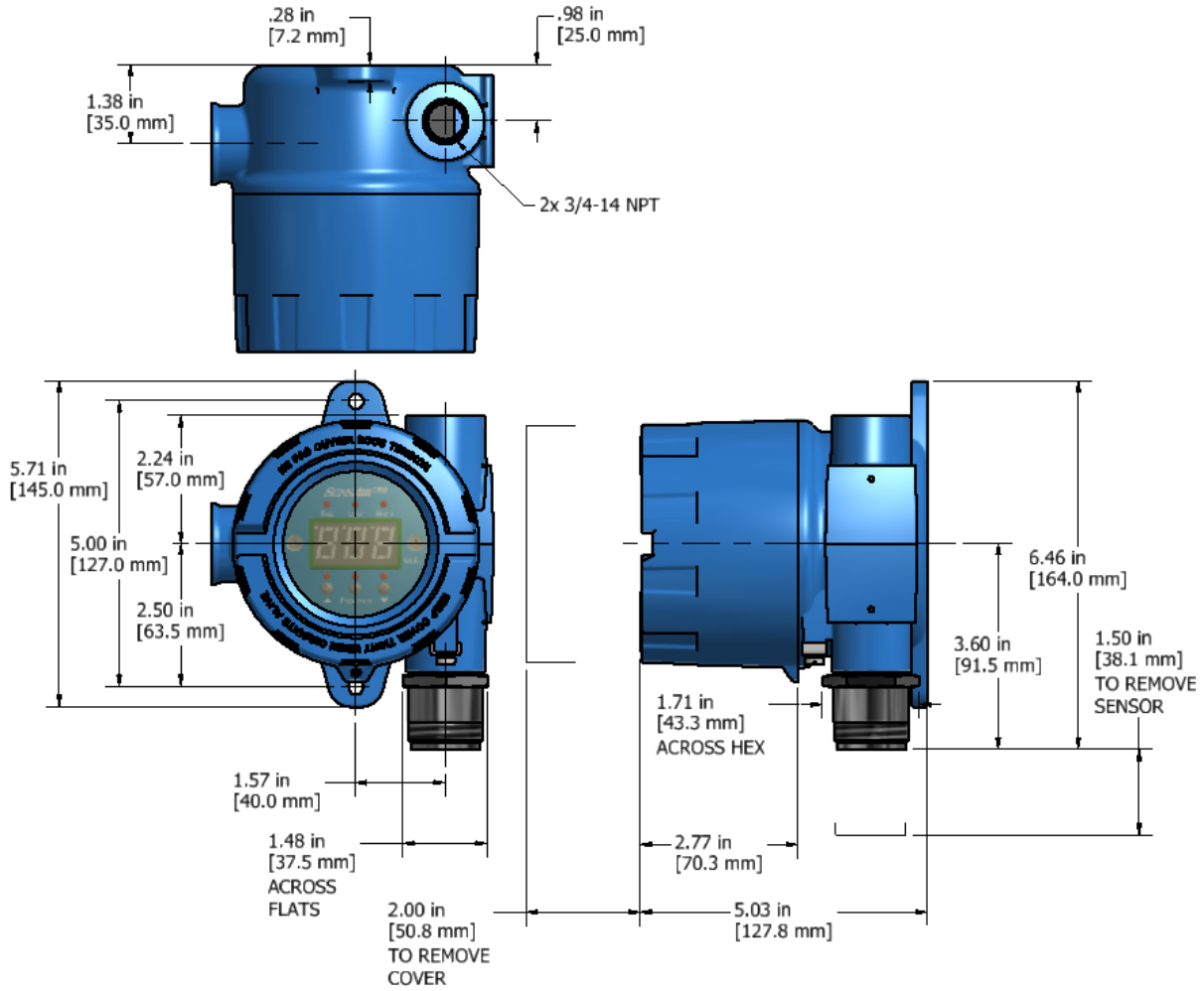

## 12 Appendix- Calibration Equipment

---

Product Number	Description
580-0001-01	Regulator (0.5 LPM), for use with all gases
7010032-1	PVC Carrying Case (holds two gas cylinders, plus regulator, tubing & fitting)
821-0604-01	Calibration Cup
7016042	Tygon® Tubing, 3/16" ID x 5/16", sold per foot

### Zero Calibration Gases

Product Number	Description
009824-15	Zero Gas for Oxygen (O <sub>2</sub> ) or Infrared sensors, 100% Nitrogen (103L)
009824-25	Zero Gas for all other sensors including Infrared, 20.9% O <sub>2</sub> in N <sub>2</sub> (103L)

### Calibration Gases

All calibration gases are in Aluminum or Steel cylinders containing either 58 SL or 103 SL of gas. Gas is shipped with a Material Safety Data Sheet (MSDS). A NIST traceable calibration certificate is available upon request.

Product Number	Description
009824-68.....	Acetylene, C <sub>2</sub> H <sub>2</sub> , 1.25%vol / 50 %LEL in Air (103 SL)
009824-6.....	Hydrogen, H <sub>2</sub> , 2 %vol / 50 %LEL in Air ((103 SL)
009824-2.....	Methane, CH <sub>4</sub> , 1.5 %vol / 30 %LEL in Air (103 SL)
009824-3.....	Methane CH <sub>4</sub> , 2.5 %vol / 50 %LEL in Air (103 SL)
009824-72.....	Pentane, 0.75%vol. / 50% LEL (103 SL)
009824-61.....	Propane C <sub>3</sub> H <sub>8</sub> , 1.05%Vol / 50 %LEL in Air (103 SL)

## **13 Appendix – Accessories and Spares**

---

<b>Product Number</b>	<b>Description</b>
821-0603-01	Sensor Shield
821-0604-01	Calibration Cup
821-0605-01	Flow Block
214-0038-11	Sensor

# 14 Appendix- Specifications

---

Sampling System .....	Diffusion
Detection Range .....	0–100 %LEL
Housing.....	Aluminum conduit
Weight .....	3.7lbs [1.7Kg]

## **Electrical Specifications**

Power Requirement .....	24 Vdc, nominal, 125 mA
Voltage .....	12-30 Volts DC
Current Maximum.....	300mA, typical 125mA
Termination Resistance .....	< 500 (250 recommended)
Grounding .....	Conduit must be earth grounded via conduit
Transmission Link .....	4–20 mA current, non-isolated 3 wires

## **Classification/Certification**

Explosion-Proof Rating .....	NEC/CEC CL1, Div 1 & Div 2 Groups A, B, C, D, T4 ATEX II 2 G Ex d IIC T4 Gb II 3 G Ex nA d IIC T4 Gc
Intrinsic Safety Rating .....	Not intrinsically safe

## **Sensor Specifications**

Minimum Detectable Concentration .....	1 %LEL Minimum Detectable Change
Repeatability .....	3% of Full Scale
Accuracy .....	10% of Indication or 5% of Full Scale, whichever is less
Zero Drift .....	1 %LEL methane/month
Span Drift .....	< 1% of signal/month
Response Time (Rise) .....	T90 < 5 sec., T50 < 4 sec.
Recovery Time (Fall).....	T10 < 30 sec
Operating Temperature Range .....	-20 to 75 C (-4 to 167 F)
Storage Temperature Range .....	-40 to 50 C (-40 to 122 F)
Operating Humidity Range.....	0-95% RH, non-condensing
Operating Pressure Range .....	Nominal pressure effect due to variation of concentration ..... resulting from compression or expansion with changing pressure
Sensor Life (Expected) .....	Standard: 1 year, normal service
Calibration Frequency .....	Monthly (recommended)
Calibration Concentration .....	30–80 %LEL of combustible substance
Calibration Flowrate .....	0.5 LPM, recommended
Oxygen Requirement .....	10% by volume, minimum

**Special State Indication**

Indication is the 4 – 20 mA current loop at a value of 3 mA or below or a value of 21.6 mA or above

**User Adjustable Parameters**

- Calibration Gas Concentration.....10 to 100 %LEL
- K-factor..... 0.5 to 3.0
- Sensor Voltage Adjust.....1.8 to 3.0 Volts
- Current Loop 4 mA Setpoint..... 1.0 to 6.8 mA
- Current Loop 20 mA Setpoint..... 12.0 to 26.0 mA

# 15 Appendix- Selectivity Factors

## Catalytic Bead Sensor Calibration and Spanning

Ideally, a combustible gas sensor should be calibrated with its target gas. In applications where methane will not be present, Sensidyne recommends the use of propane as a calibration gas or as span gas in conjunction with propane/target gas specific selectivity factors. It is recognized that many combustible gases are not readily available for calibration – in these instances it is an accepted industry practice to use a standard gas, typically methane or propane, in conjunction with selectivity factors (also known as k-factors) for setting a sensor's span. Catalytic bead combustible sensor characteristics govern the recommendations for when to use methane or propane for calibration or surrogate span purposes. Catalytic bead sensors can lose sensitivity due to various factors with sensor aging, overexposure, poisoning, or inhibition as typical factors. Due to methane gas combustion characteristics, catalytic bead sensors will lose sensitivity to methane prior to losing sensitivity for other gases. In applications where methane is the target gas or methane may be present with other gases, sensor calibration or surrogate spanning must be performed using methane gas with selectivity factors specific to methane and the target gas. In these applications, spanning with a gas other than methane can create unsafe conditions. In applications where methane will not be present, spanning with methane could result in loss of accuracy for the target gases as the sensor loses sensitivity to methane and retains (higher) sensitivity to the target gas.

Substance	Methane K-Factor	Propane K-Factor
Methane	1.00	0.56
Acetaldehyde	1.7	1.0
Acetic Acid	1.9	1.1
Acetic Anhydride	2.2	1.2
Acetone	1.9	1.1
Acetylene	1.8	1.0
Allyl Alcohol	2.0	1.1
Ammonia	0.8	0.4
n-Amyl Alcohol	3.0	1.7
Aniline	2.6	1.5
Benzene	2.4	1.3
Biphenyl	4.0	2.2
1,3-Butadiene	1.8	1.0
n-Butane	1.7	1.0
1-Butane	2.2	1.2
cis-2-Butane	2.1	1.2
trans-2-Butane	2.0	1.1
n-Butyl Alcohol	2.9	1.6
tert-Butyl Alcohol	1.4	0.8
n-Butyl Benzene	3.2	1.8
n-Butyric Acid	2.6	1.5
Carbon Monoxide	1.3	0.7
Cyanogen	1.1	0.6
Cyclohexane	2.4	1.3
Cyclopropane	1.6	0.9
n-Decane	3.0	1.7
Diethylamine	2.0	1.1

*(table continues on next page)*

Substance	Methane K-Factor	Propane K-Factor
Methane	1.00	0.56
Dimethylamine	1.7	1.0
2,3-Dimethyl	2.5	1.4
2,2-Dimethyl	2.5	1.4
1,4-Dioxane	2.2	1.2
Ethane	1.5	0.8
Ethyl Acetate	2	1.1
Ethyl Alcohol	1.4	0.8
Ethylamine	1.9	1.1
Ethylbenzene	2.8	1.6
Ethylcyclopentane	2.5	1.4
Ethylene	1.4	0.8
Ethylene Oxide	1.9	1.1
Ethyl Ether	2.2	1.2
Ethyl Formate	2.3	1.3
n-Heptane	2.6	1.5
n-Hexane	2.7	1.5
Hydrazine	2.2	1.2
Hydrogen	1.3	0.7
Hydrogen Cyanide	2.1	1.2
Isobutane	1.9	1.1
Isobutyl Alcohol	1.9	1.1
Isobutyl Benzene	3.1	1.7
Isopentane	2.2	1.2
Isopropyl Ether	2.3	1.3
Methyl Acetate	2	1.1
Methyl Alcohol	1.2	0.7

*(table continues on next page)*



Substance	Methane K-Factor	Propane K-Factor
Methane	1.00	0.56
Methylamine	1.3	0.7
Methylcyclohexane	2.3	1.3
Methyl Ether	1.6	0.9
Methyl Ethyl Ether	2.3	1.3
Methyl Ethyl Ketone	2.4	1.3
Methyl Formate	1.5	0.8
Methyl Propionate	2	1.1
Methyl Propyl	2.4	1.3
Napthalene	2.9	1.6
Nitromethane	13.7	7.7
-Nonane	3.2	1.8
n-Octane	2.7	1.5
n-Pentane	2.2	1.2
Propane	1.8	1.0
n-Propyl Alcohol	2.1	1.2
n-Propylamine	2.1	1.2
Propylene	1.9	1.1
Propylene Oxide	2.2	1.2
Propyne	2.4	1.3
Toluene	2.5	1.4
Triethylamine	2.5	1.4
Trimehtylamine	2.1	1.2
Vinyl Ethyl Ether	2.4	1.3
m-Xylene	2.6	1.5
o-Xylene	2.8	1.6
p-Xylene	2.6	1.5

Appendix- Allowable Line Lengths

Power Supply Voltage (Vdc)	4-20mA Termination (Ohms)	Allowable Loop Resistance (Ohms)	Wire Gauge	Allowable Line Length (Feet)	Allowable Line Length (Meters)
30	250	110	14	27,000	8,200
			16	17,000	5,150
			18	10,600	3,250
			20	6,050	1,800
			24	4,200	1,250
28	250	95	14	23,400	7,100
			16	14,700	4,450
			18	9,200	2,800
			20	5,200	1,550
			24	2,300	700
26	250	80	14	19,800	6,000
			16	12,400	3,800
			18	7,800	2,350
			20	4,400	1,350
			24	1,950	550
24	250	65	14	16,200	4,900
			16	10,200	3,100
			18	6,350	1,950
			20	3,600	1,100
			24	1,600	490
22	250	58	14	12,600	3,800
			16	7,900	2,400
			18	4,950	1,500
			20	2,800	850
			24	1,250	380
20	250	51	14	9,000	2,700
			16	5,650	1,700
			18	3,550	1,050
			20	2,000	600
			24	850	270
18	250	20	14	5,400	1,600
			16	3,400	1,000
			18	2,100	650
			20	1,200	360
			24	500	160
16	250	14	14	1,800	500
			16	1,100	340
			18	700	210
			20	400	120
			24	170	50

# 16 Appendix- Troubleshooting Guide

Problem	Cause	Remedy
	No power to the transmitter.	Apply 12-30Vdc.
	Power input and 4-20mA output wires are reversed.	Verify positive voltage at the power input.
	Power supply voltage is less than 12Vdc.	Verify power supply voltage to be 12-30Vdc.
	There is no connection between the power supply and the current output of the transmitter.	Verify wiring.
	Sensor is incorrectly installed.	Verify wiring.
	Power supply voltage is greater than 30Vdc.	Verify power supply voltage to be 12-30Vdc.
	Sensor assembly is defective.	Disconnect sensor assembly. Measure the resistance between the colored wires. If resistance is between any pair of wires is <1ohm or >5ohms, replace sensor.
	Electronics board is defective.	Replace electronics board.
Unable to attain 4mA output current.	Current output of transmitter is shorted.	Verify wiring.
	4mA is misadjusted.	Adjust the 4mA level.
	Electronics board is defective.	Replace electronics board.
Unable to attain output current corresponding to %LEL concentration.	Actual concentration of calibration substance is not the expected concentration.	Verify the concentration of the calibration substance. Replace the calibration substance and/or assure proper delivery of the calibration substance to the sensor.
	Actual concentration of calibration substance is not the expected concentration.	Verify that the outside of the sensor assembly is clean. Blow away any debris on the sensor assy with "zero grade" air if necessary.
	4mA is misadjusted.	Adjust the 4mA level.
	Sensor assembly is defective.	Disconnect sensor assembly. Measure the resistance between the colored wires. If resistance is between any pair of wires is <1ohm or >5ohms, replace sensor.
	Electronics board is defective.	Replace electronics board.

# 17 Returned Material Authorization

---

Sensidyne maintains an instrument service facility at the factory to provide its customers with both warranty and non-warranty repair. Sensidyne assumes no liability for service performed by personnel other than authorized Sensidyne authorized personnel. To facilitate the repair process, please contact the Sensidyne Service Department in advance for assistance with a problem which cannot be remedied and/or requires the return of the product to the factory. All returned products require a Returned Material Authorization (RMA) number. Sensidyne Service Department personnel may be reached at:

**Sensidyne, LP**  
**1000 112<sup>th</sup> Circle N, Suite 100**  
**St. Petersburg, FL 33716 USA**  
**800-451-9444 • +1 727-530-3602**  
**+1 727-538-0671 [Service Fax] email: info@sensidyne.com**

All non-warranty repair orders will have a minimum fee assessed whether the repair is authorized or not. This fee includes handling, administration and technical expenses for inspecting the instrument and providing an estimate. However, the estimate fee is waived if the repair is authorized.

If you wish to set a limit to the authorized repair cost, state a “not to exceed” figure on your purchase order. Please indicate if a price quotation is required before authorization of the repair cost, understanding that this invokes extra cost and handling delay. Sensidyne’s repair policy is to perform all needed repairs to restore the instrument to its full operating condition.

Repairs are handled on a “first in - first out” basis. Your order may be expedited if you authorize an expediting fee. This will place your order next in line behind orders currently in process.

Pack the instrument and its accessories (preferably in their original packing) and enclose your return address, purchase order, shipping and billing information, RMA number, a description of the problem encountered with your instrument and any special instructions. All prices are subject to change without notice.

If this is the first time you are dealing directly with the factory, you will be asked to prepay or to authorize a COD shipment.

Send the instrument, prepaid, to:

**SENSIDYNE**  
**1000 112<sup>th</sup> Circle N, Suite 100**  
**St. Petersburg, FL 33716 USA**  
**ATTENTION: Service Department**  
**RMA #: \_\_\_\_\_**

## SERVICE OPTIONS

The Sensidyne Service Department offers a variety of service options which will minimize costly interruptions and maintenance costs. These options include initial training, on-site technical assistance, and full factory repairs. Sensidyne has developed several programs which offer options best suited to your applications and needs. For further information, contact the Sensidyne Service Department at the following numbers: 800-451-9444 • +1 727-530-3602 • +1 727-538-0671 [Service Fax].

# 18 Approval Ratings

---

## SensAir Cmb HD Div1

**WARNING:** Substitution of components may impair suitability for Division 1.

**WARNING:** Do not open enclosure while circuits are live, or when combustible vapors may be present.



**CAUTION:** Read and understand instruction manual before operating or servicing.

Install in accordance with Control Drawing Number 099-2014-01.



NEC/CEC CL I, DIV 1, GPS A, B, C, D, T4  
FM6320, C22.1 No. 152. Not including ketones, alcohols, esters and acidic atmospheres.

CE 0518  II 2 G Ex d IIC T4 Gb Ta = -20°C to +75°C FM13ATEX0066

**Input Ratings:** 12-30VDC 500mA 6W

---

## SensAir Cmb HD Div2

**WARNING:** Substitution of components may impair suitability for Division 2.

**WARNING:** Do not open enclosure while circuits are live, or when combustible vapors may be present.



**CAUTION:** Read and understand instruction manual before operating or servicing.

Install in accordance with Control Drawing Number 099-2014-02.



NEC/CEC CL I, DIV 2, GPS A, B, C, D, T4  
FM6320, C22.1 No. 152. Not including ketones, alcohols, esters and acidic atmospheres.

 II 3 G Ex nA d IIC T4 Gc Ta = -20°C to +75°C FM13ATEX0084

**Input Ratings:** 12-30VDC 500mA 6W

# 19 Control Drawings

• Control Drawing Number 099-2014-01

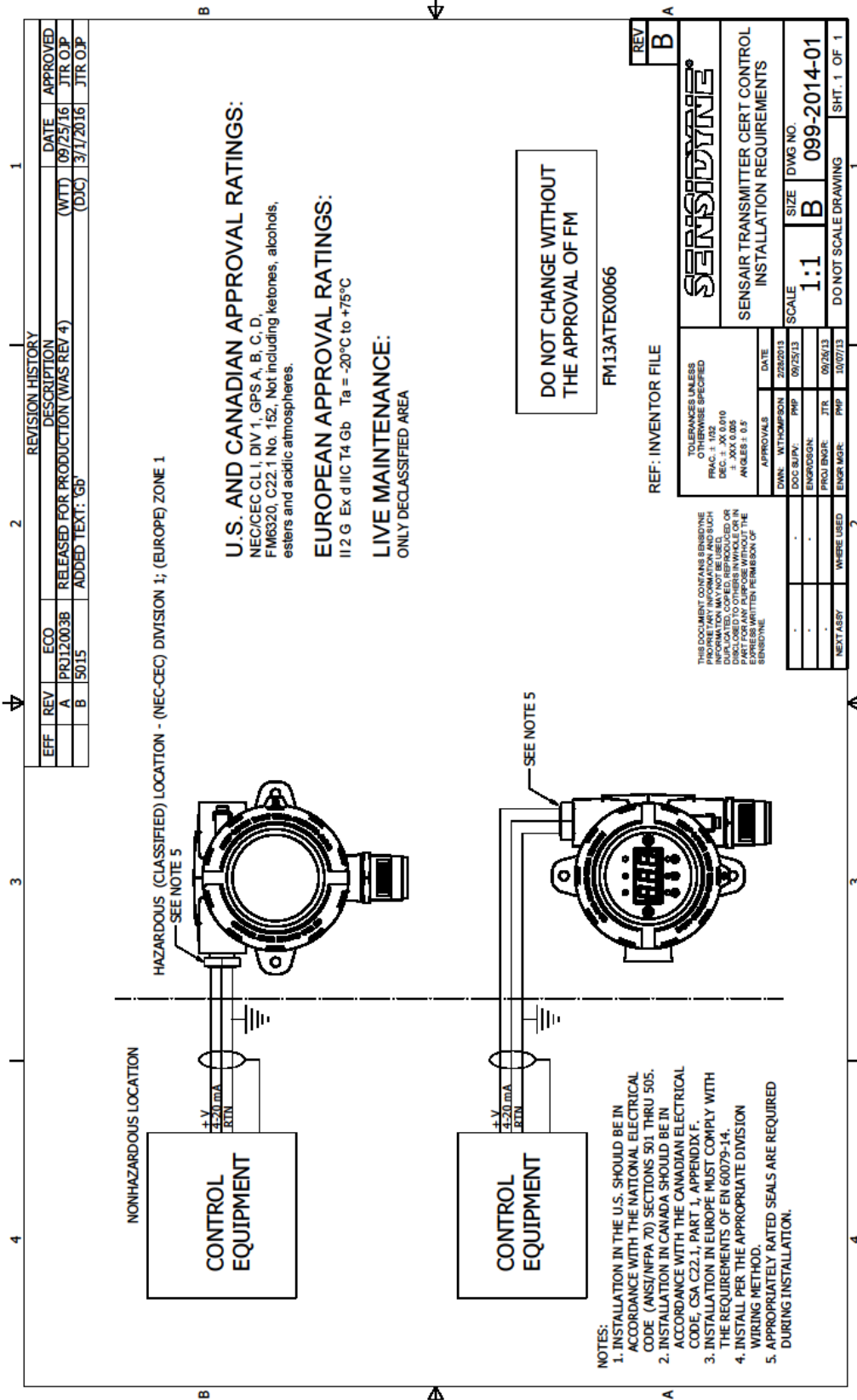



# Notes



# Notes



**Manufactured by:**

Sensidyne, LP  
1000 112<sup>th</sup> Circle N, Suite 100  
St. Petersburg, Florida 33716  
USA

800-451-9444 • 727-530-3602 • 727-539-0550 [fax]  
www.Sensidyne.com • info@sensidyne.com

**Authorized EU Representative**

Schauenburg Electronic Technologies GmbH  
Weseler Str. 35 · 45478  
Mülheim-Ruhr Germany

+49 (0) 208 9 99 10 • +49 (0) 208 5 41 10 [fax]  
www.schauenburg.com • international@schauenburg.com

***SENSIDYNE***<sup>®</sup>

Sensidyne, LP • 1000 112<sup>th</sup> Circle N, Suite 100  
St. Petersburg, Florida 33716 USA  
800-451-9444 • +1 727-530-3602 • +1 727-539-0550 [fax]  
web: [www.sensidyne.com](http://www.sensidyne.com) • e-mail: [info@sensidyne.com](mailto:info@sensidyne.com)



**Intertek**

